



AMAZONE

Pantera



Pantera 4504 and 7004 self-propelled sprayers



- ✔ On request, all new AMAZONE sprayers can be provided with an official sprayer proficiency certificate. The proficiency certificate meets current EU regulations according to EN ISO 16122, which is, for European member states, supported also with the CEMA label.

The Pantera self-propelled sprayers come with a tank capacity of either 4,500 l or 6,600 l and can be equipped with sprayer booms in widths from 21 m to 48 m. Stepless track width adjustment as standard makes the Pantera a universal all-rounder, particularly when shared across neighbouring farms. A wide variety of requirements can be met thanks to the different chassis options. The Pantera focuses on increasing work rates as well as reducing the work load on the driver.



More intelligence, more precision

| | Page |
|---|------|
| Pantera 4504– The advantages at a glance | 4 |
| Pantera 4504 – Standard equipment | 6 |
| Pantera 4504 – Intelligent chassis management | 8 |
| Pantera 4504 – Intelligent drive management | 14 |
| Pantera 4504 – Intelligent cab management | 18 |
| Pantera 4504 – Intelligent operation management | 20 |
| Pantera 7004 – The advantages at a glance | 22 |
| Pantera 7004 – Standard equipment | 24 |
| Pantera 7004 – Intelligent chassis management | 26 |
| Pantera 7004 – Intelligent drive management | 28 |
| Pantera 7004 – Intelligent cab management | 32 |
| Pantera 7004 – Intelligent operation management | 34 |
| ISOBUS | 36 |
| Intelligent steering management | 41 |
| Intelligent liquid management | 44 |
| Boom | 54 |
| Part-width section control | |
| Pressure recirculation system | 68 |
| Electric individual nozzle control | 70 |
| AmaSelect CurveControl | 76 |
| AmaSelect Row | 78 |
| AmaSelect Spot | 82 |
| Nozzles | 84 |
| End nozzle control Liquid fertilisation | 86 |
| Equipment | 88 |
| AMAZONE service | 90 |
| Tyres | 92 |
| Technical data | 94 |

Learn more about operating the machine
Click here to go to SmartLearning:



www.amazone.net/smartlearning

Pantera 4504 self-propelled sprayer

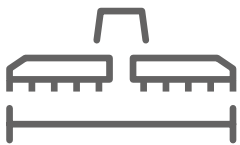

21 m – 48 m



4,500 l



up to 96 part-width sections



520 l/min
pump capacity

The advantages at a glance:

- + Outstanding tandem chassis design – for a smooth horizontal boom ride and better stability on slopes
- + Intelligent chassis management with front wheel, all-wheel and dog leg steering for even greater manoeuvrability
- + Infinitely variable hydrostatic single range drive – for speeds from 0 to 50 km/h
- + Working speeds of up to 30 km/h ensure high outputs
- + Performance when needed. ECO mode and POWER mode
- + Pantera⁺ drive hubs for improved climbing ability in hilly terrain
- + DistanceControl or ContourControl and SwingStop fully automatic boom guidance system

MORE INFORMATION

www.amazone.net/pantera



PRODUCT FILM
Find out more



DOWNLOADS
mySprayer App



SMARTLEARNING
www.amazone.net/smartlearning

Standard equipment for the Pantera 4504

- ✔ Hydro-pneumatic suspended tandem chassis with automatic level regulation as well as level-regulated and forward-speed related suspension control
- ✔ Track widths from 1.80 m to 3.20 m (will differ depending on the chassis type and tyres); the track width can be adjusted steplessly via the AmaDrive vehicle terminal
- ✔ Hydraulic front-wheel steering, all-wheel steering and dog-leg steering; steering angles tailored to the speed and operation
- ✔ Headland management with automated switch from front-wheel to all-wheel steering, boom lift with AutoLift
- ✔ Forward speeds up to 50 km/h, infinitely variable hydrostatic single range transmission with traction control
- ✔ Hydraulic braking system with disc brakes and hydraulic parking brake
- ✔ 6 cyl. Deutz turbodiesel engine, Common-Rail injection technology, maximum power 160 kW (218 hp) according to ISO 14396, Stage 3A or Stage 5 exhaust emissions compliant
- ✔ ECO-Mode: fuel saving, performance-related engine rev regulation on the road and in the field





- ✔ 290 l fuel tank; Stage 5 exhaust emission compliant with 20 l DEF tank (Diesel Exhaust Fluid, e.g. AdBlue)
- ✔ Claas Vista cab, climate control, heating, air-suspended comfort seat, adjustable steering column, radio with USB SD slot, Bluetooth hands-free phone connectivity, windscreen and rear window sunblinds
- ✔ AmaDrive vehicle terminal with colour touchscreen (7") for vehicle operation
- ✔ AmaPilot multi-function joystick⁺ for drive control and sprayer operation
- ✔ Side lights, dip and main beam headlights, 4 front work lights, 2 side work lights and 2 side view work lights in the cab roof, front illumination of the boom as well as illumination of the operator station.
- ✔ 4,500 l spray agent tank with agitator, fill level indicator, tank cleaning nozzles; 500 l fresh water tank and induction bowl
- ✔ 520 l/min pump capacity with 3" suction port, max. suction capacity 700 l/min via the venturi
- ✔ Pump speed set from the terminal and remote control of the pump down at the operator station.
- ✔ Suction valve with 3" suction filter (32 mesh) and fill port for fresh water tank
- ✔ Valve chest, self-cleaning 1 1/4" pressure filter (50 mesh) and part-width section control, quick emptying
- ✔ Comfort-Pack with digital external fill level indicator, automatic fill stop, fill-level dependent and auto-dynamic agitation regulation and remote-controlled cleaning from the cab
- ✔ Super-light and super-stable Super-L boom
- ✔ Spraying height 0.35 m - 2.65 m, up to 3.15 m on the Pantera-HW and Pantera-H (with 380/90 R50 tyre sizes)



Pantera 4504

Intelligent chassis management

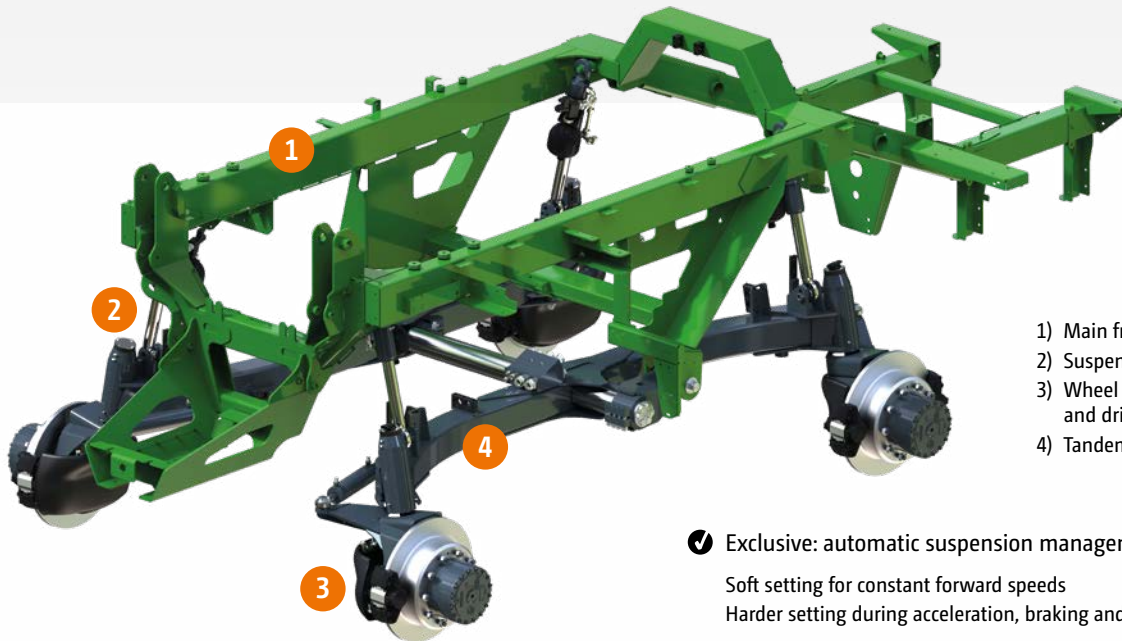

- 1) Main frame
- 2) Suspension
- 3) Wheel motor with disc brakes and drive hubs
- 4) Tandem chassis

- ✔ Exclusive: automatic suspension management
Soft setting for constant forward speeds
Harder setting during acceleration, braking and manoeuvring

The outstanding longitudinal tandem chassis

AMAZONE Pantera

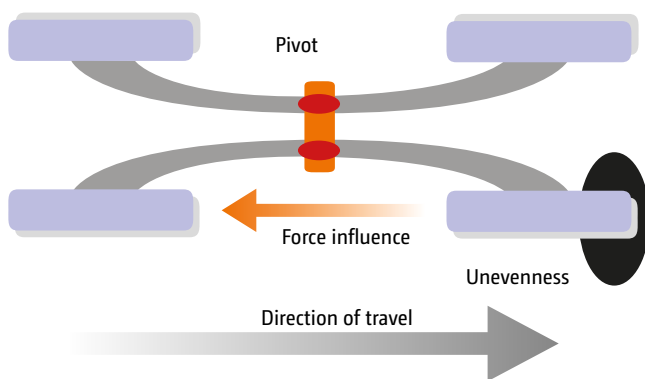

Conventional chassis

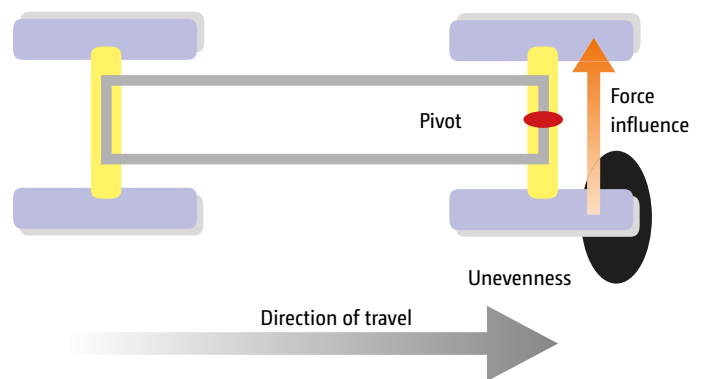

- ✔ The unevenness under the right hand front wheel is compensated by the elongated tandem. The pivot point is only slightly lifted.
Only a slight transmission of the forces onto the frame.

The advantages of the Pantera chassis:

- ✔ Pendulum frame for optimised soil contact and reduced slip
- ✔ Comfortable and safe driving behaviour from the longitudinal tandem
- ✔ Hydro-pneumatic suspension system with level regulation
- ✔ Super-robust frame
- ✔ Reliable hydraulic system – no air regulation
- ✔ Stepless track width adjustment
- ✔ High ground clearance
- ✔ Headland management for steering and boom functions
- ✔ Stress relief for the driver and gentle boom treatment



Weight distribution when full and with the booms folded out

Pantera 4504, 24 m, 520/85R38, unladen weight 9,850 kg

Pantera – light-footed intelligence

The special tandem chassis design of the Pantera not only ensures perfect adaptation to ground undulations but also an optimum boom ride – especially, of course, in sloping terrain. Thanks to the level regulated hydro-pneumatic suspension, the Pantera operator also enjoys the maximum level of comfort.

The combination of this unique chassis design and the proven AMAZONE boom suspension additionally ensures an optimally smooth boom ride even under the most arduous of conditions.

Nearly unbounded – exceptional ground clearance

The high ground clearance of 1.20 m also proves to be an important advantage for the Pantera in practice. The Pantera-H and Pantera-HW even have a ground clearance of 1.70 m. This is an advantage that is of particular benefit when spraying rape during flowering or also in taller maize crops. The SunflowerKit is available for the Pantera-HW, in order to enhance the plant care (see page 13).

Weight distribution at the optimum!

Even weight distribution between the front and rear wheels is one of the basic requirements for efficient power transfer to the ground.

The Pantera 4504 was therefore designed to have an optimal weight distribution of approximately 50% on both the front and the rear axles when the tank is full. Depending on the tank level and the boom type, the weight distribution varies only by around 5%.



High ground clearance for minimisation of crop damage

Pantera 4504

Track width adjustment in no time at all



Maximum flexibility offered by the chassis variants on the Pantera 4504

The standard, automatic track width adjustment allows a quick response to different applications and crops. Once the desired track width has been pre-selected, the exact centimetre precise setting is carried out automatically.



✔ Wheel motor guards on the Pantera 4504 as standard

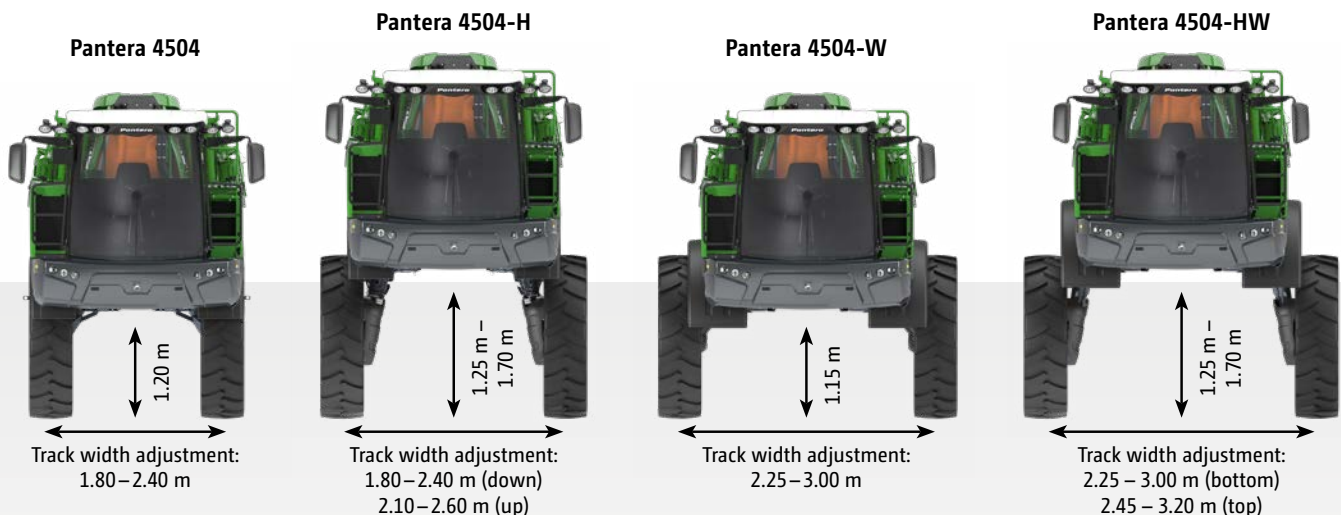

Track width and ground clearance respectively with tyre sizes 380/90 R50 (offset depth + 50 mm)

Pantera 4504-H

Ground clearance up to 1.70 m

Increased flexibility

The driver can lift the machine up to a ground clearance of 1.70 m at the touch of a button on the operator terminal. The track width can be adjusted between 2.10 m and 2.60 m with the machine in the lifted position.

The broad track width spectrum makes it possible to vary the track width of the machine from 1.80 m to 2.40 m in normal applications which only require a 1.25 m ground clearance.

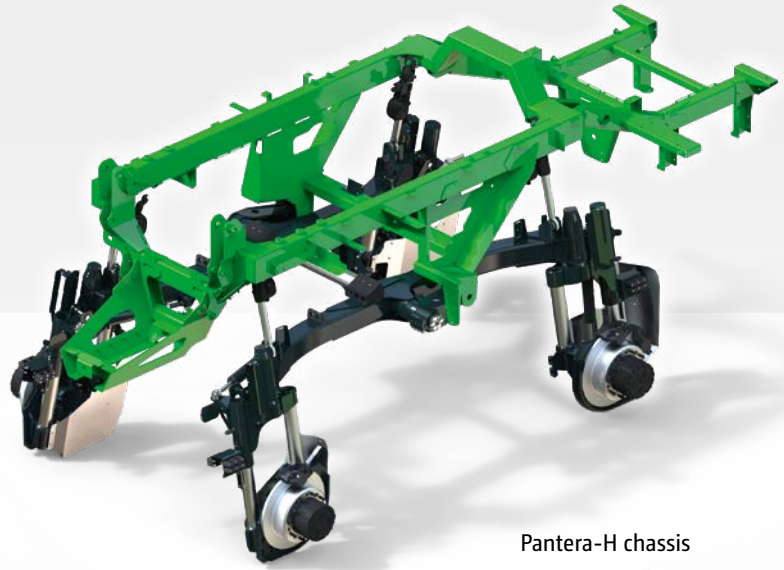

Pantera-H chassis

The advantages of the Pantera-H chassis:

- ✔ Ground clearance from 1.25 m to 1.70 m, depending on the tyre sizes
- ✔ Sufficient room in all crops without plant damage

Pantera 4504-W

Track width adjustment up to 3 m

Enhanced flexibility

The Pantera 4504-W is equipped with track width adjustment from 2.25 m to 3.00 m. In "Controlled Traffic Farming" systems, the track width potential of the Pantera-W provides the ideal alternative. This specification is also of advantage if working in potato crops without tramlines: four rows of potatoes under the machine provide high stability and ensure minimal plant damage.

The advantages of the Pantera-W chassis:

- ✔ Stepless track width adjustment from 2.25 m to 3.00 m, depending on the tyre sizes
- ✔ High flexibility and therefore minimal damage to plants
- ✔ Compliance with the permissible transport widths



3 m

Pantera 4504-HW

For tremendous stability



Maximum flexibility

The Pantera-HW self-propelled sprayer is extremely versatile with a track width adjustment range from
 - 2.25 m to 3.00 m with a 1.25 m ground clearance or
 - 2.45 m to 3.20 m (3.30 m) with a 1.70 m ground clearance.

In spite of its higher centre of gravity, the Pantera 4504-HW turns out to be very stable and can be flexibly used in a wide variety of crops and row spacings. In particular, contractors looking to offer a flexible plant protection service across a wide range of customers and crops can clearly increase the scope of crop protection treatments possible.

The advantages of the Pantera-HW chassis:

- ✔ Angled lifting cylinders provide tremendous stability
- ✔ Larger track width in combination with the high-clearance chassis for maximum flexibility

Lift module

The optional Lifti module 700 can be used to raise the Super-L2 boom by a further 70 cm. In combination with this Lift module, the Pantera-H or Pantera-HW has an application height of 3.85 m* measured from the lower edge of the nozzle.

The Lift module is available for the Super-L2 boom and across all chassis versions.



1.70 m ground clearance

3.85 m lift height
 (*with tyre sizes 380/90 R50)



Wheel motor guards on the Pantera-H and Pantera-HW



Wheel gearbox cover

Crop divider

Better protection for both machine and crop

In addition to the standard drive wheel motor guards, AMAZONE offers an additional range of special equipment, such as the drive wheel gearbox covers, crop dividers and the underbelly cover.



SunflowerKit

The crop-saving SunflowerKit

The SunflowerKit was specially developed for the Pantera-HW, in order to be able to carry out plant protection and fertiliser applications in tall sunflower crops without causing too much plant damage. The kit consists of crop dividers, wheel housings and a shaped, flexible underbelly sheet.

The crop dividers precisely separate the plants between the rows directly in front of the tyres. Thanks to the profile of the underbelly sheet and the properties of the flexible material, the sunflowers gently slide under the machine without hindrance.



Drive management with optimised fuel efficiency

Pantera – high-powered intelligence

Stage 5 emissions compliant engine

The new Stage 5 emission compliant engine from AMAZONE uses exhaust gas recirculation, a diesel oxidation catalyst and a diesel particle filter to help protect the environment. The diesel particulate filter is continuously regenerating during operation. The SCR catalytic converter reduces the levels of nitrogen oxide with the aid of a diesel exhaust fluid (DEF) injection. The new 20 litre DEF tank is positioned at the side of the 290 litre diesel tank. The DEF consumption amounts to approximately 2.5% of the fuel consumption. This means that the DEF only requires refilling every 3 or 4 tankfuls.

The benefits:

- ✔ Stepless hydrostatic drive from 0 to 50 km/h*
- ✔ State-of-the-art fuel management on the road and in the field with ECO and POWER mode
- ✔ Tailor-made speed regulated radiator fan drive
- ✔ Proven Deutz technology with a comprehensive service network

The heart as a unit: engine and hydrostatic drive

Deutz 6-cylinder diesel engine with a maximum output of 160 kW (218 hp)

- ✔ Turbocharger with intercooler
- ✔ Common-Rail injection technology
- ✔ 6.06 litre capacity
- ✔ Country-specific execution according to either Stage 3A or Stage 5 emission compliance

- ❗ "The Amazone Pantera impresses with its low diesel consumption, the minimal noise level, the good weight distribution and sufficient payload."
(profi 12/2011)

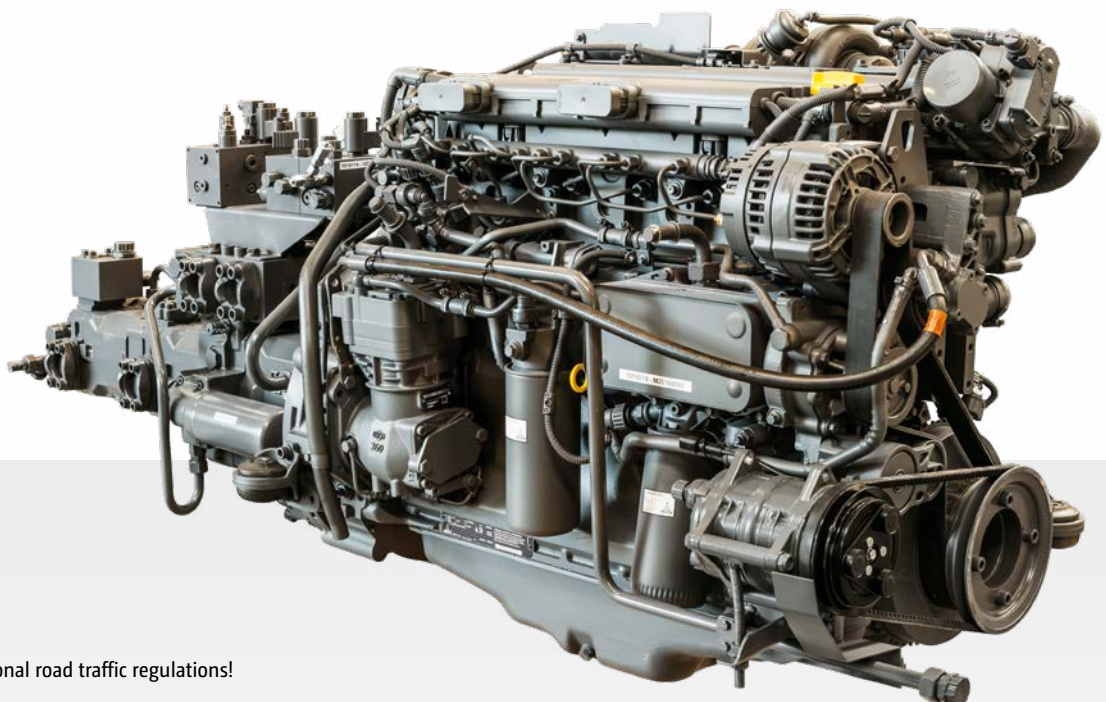

* Please be aware of national road traffic regulations!

The benefits of the clever cooling system:

- ✔ Revs on demand
- ✔ The fans even switch off under low power demands and cool temperatures
- ✔ Positioned beyond the reach of dirt left: charge air, hydraulics right: engine, air-conditioning

**Operation at optimum fuel saving: ECO or POWER**

The new and optimised engine rev regulation mean that you can always operate the Pantera at the optimum fuel consumption efficiency.

When ECO Mode has been selected in the AmaDrive vehicle terminal, the engine will search for the optimal operating point for torque and revs in the given driving situation.

When spraying on the flat, an engine rev reduction down to 950 rpm is possible. This finely tuned, automatic adaptation of engine speed takes place continuously between 950 and 2,000 rpm.

However, when working on steep slopes, or operating with a full tank in hilly terrain, maximum power at up to 2,000 rpm can be drawn upon by using the POWER Mode.

Example in ECO mode

- 1) **Around 80 kW is required on the flat**
- 2) **When the machine is climbing a hill, the torque increases under load.** The speed remains constant.
- 3) **The climb is harder: the power consumption increases to 120 kW.** The speed remains constant with slightly increased fuel consumption.

Infinitely variable power

The powerful Deutz 6-cylinder diesel engine with Common-Rail injection technology provides 218 hp and impresses by its high performance yet low fuel consumption. Thanks to the modern hydrostatic drive mechanism, you can drive the Pantera with absolute infinite variability.

This system allows, even at a low engine speeds, high start-up torques and a very dynamic acceleration.

Good power/weight ratio

The low unladen weight of the Pantera 4504 (9,900 kg in a 24 metre working width) is another advantage with regard to its low fuel consumption. So, the fuel tank volume of 290 litres enables high work rates over long days.



- ✔ Integrated DEF tank for the Pantera with its Stage 5 emission compliant engine

Drive and brake management

Your safety is paramount!



❗ "The Amazone Pantera shows very good driving behaviour with a speed of 42 km/h at just 1400 revs."
(profi 12/2011)

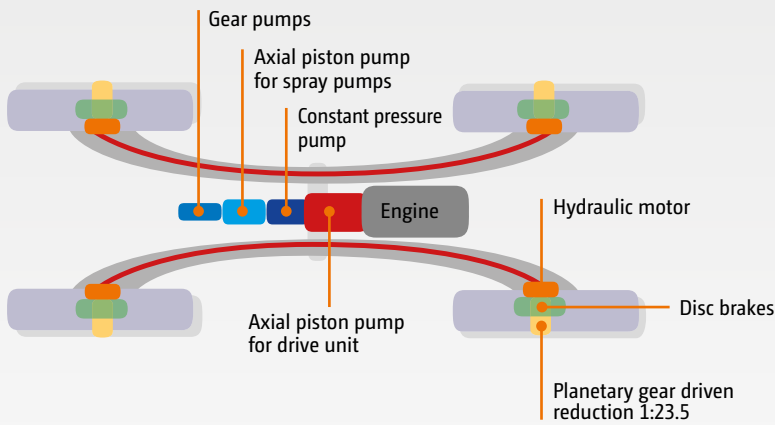

Drive and brake management

Pantera – Reliable intelligence

Due to the large wheel diameter, particularly high torques are necessary when starting off. The intelligent drive concept of the Pantera does not build up these high forces hydraulically but mechanically via the fixed reduction ratio of the planetary gearbox. This is an extremely reliable drive under difficult ground conditions and when starting off.

Traction control as standard

The drive torque of the four wheel motors is constantly being monitored electronically and then regulated to ensure the optimum vehicle behaviour even under difficult conditions. Power-consuming differential locks are avoided. Traction control (TCS) also ensures safe driving on the road at all times.

Advantages of the drive system:

- ✔ High torque at all times
- ✔ No speed change steps
- ✔ A fixed reduction ratio in the planetary gearboxes drives the wheels

Pantera⁺ drive concept – Powerful intelligence

With the Pantera⁺, AMAZONE offers a drive concept that is particularly suitable for extreme terrain in hilly areas. Instead of the standard wheel drive hubs, all the Pantera models can be equipped with an alternative wheel hub with a gear reduction ratio of 1:30 (instead of 1:23.5). The Pantera⁺ has significantly more power with the alternative wheel drive hubs. The maximum speed is 40 km/h.

Pantera – Safe intelligence

When the speed is reduced via the drive lever, the Pantera's hydrostatic brake is activated and the vehicle is braked down to a complete stop without fuss. In addition, the Pantera has a hydraulic braking system with disc brakes, which are applied via a foot pedal. The drive stops automatically when they are applied.

Advantages of the braking system:

- ✔ Safe and elegant driving performance
- ✔ Reliable braking performance, even during emergency stops from 50 km/h
- ✔ Automatic activation of the parking brake when standing still
- ✔ Autohold assist when starting off on a slope

Cab management

A professional working environment – get on board and off you go!



- ❗ "The cab [...] is spacious and pleasantly quiet."
 (traction magazine "Working Test Pantera 4502-H" · 2/2015)

Relax ...

... when you sit in this cab

Advantages of the cab:

- ✔ Good all-round visibility
- ✔ Superb sound insulation
- ✔ Convenient, wide access with hydraulically folding ladder
- ✔ Individually adjustable air-suspended comfort driver seat with leather option, seat ventilation and seat heating
- ✔ Large folding passenger seat
- ✔ Adjustable steering column
- ✔ Height and longitudinally adjustable arm rest with integrated controls
- ✔ Climate control
- ✔ Active carbon filters or optional Category 4 cab air filtration system
- ✔ Electrically adjustable and heated exterior mirrors
- ✔ Additional mirror for best view of the front wheel
- ✔ Document compartment
- ✔ Large cool box under the passenger seat
- ✔ Radio with USB SD slot, Bluetooth hands-free connectivity
- ✔ Sun blinds for front and rear windcreens

- ✔ The optional Category 4 cab air filtration system creates an overpressure, so that the ingress of dust and vapour is prevented.



By day and night - illumination for long and safe working days

- 1) LED individual nozzle lighting (option)
- 2) Work lighting (2 halogen spotlights)*
- 3) Boom work lights (2 halogen spotlights)*
- 4) Side-view work lights (2 halogen spotlights)*
- 5) Side work lights (4 halogen spotlights)*
- 6) Front headlights (4 halogen spotlights)*

* Lights 2) to 6), also optionally available as LED lights

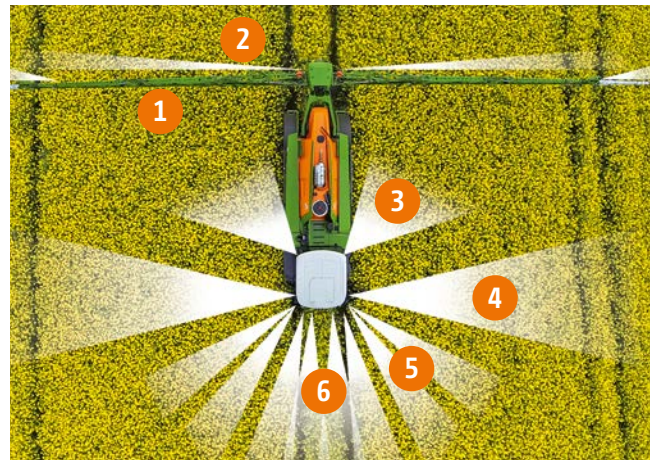

- ✔ Standard LED rear lights

Everything safely stowed!

The storage compartment under the cab offers sufficient space for convenient storage of, for instance, spray agent canisters.

A tool box is located under the steps to the cab.



- ✔ Convenient and large – compartment for such as spray canisters



- ✔ Tool box under the cab

Operation management

Everything under control, everything in view

Twin terminal solution for comfortable operation

ISOBUS terminal for operation of the sprayer

The TopCon X35 operator terminal with a 12.1" display and the AmaTron 4 operator terminal with an 8" display are offered for ISOBUS control. Both terminals have a multi-touch colour display. The practical MiniView layout means that handling is extremely comfortable and meets the highest demands of Precision Farming. The sprayer can be conveniently operated via the freely programmable AmaPilot⁺ multi-function joystick.

AmaDrive 7.0 vehicle terminal

The new AmaDrive 7.0 vehicle terminal is integrated in the ergonomic armrest. All vehicle-specific functions can be clearly displayed and intuitively operated on the colour 7" touchscreen. This is provided by the self-explanatory operating structure without multi-level sub-menus, which can be used to control the most important settings from the main screen. The freely configurable status bar means that particularly relevant information is always in view. Switching between day and night mode also makes operation easier.



Twin-terminal solution with the TopCon X35 ISOBUS terminal and AmaDrive 7.0 vehicle terminal as well as the AmaPilot⁺ multi-function joystick

Control the following functions

with the AmaDrive 7.0 vehicle terminal:

- ✔ Cruise control
- ✔ Engine management with ECO or POWER mode
- ✔ Steering and headland management
- ✔ Track width adjustment
- ✔ Vehicle lighting
- ✔ Control of the central lubrication system

Display of:

- ✔ Forward speed and engine revs
- ✔ Fuel tank level and engine temperature
- ✔ Diagnostic data of engine and hydraulic system
- ✔ Field and road modes



Perfect ergonomics thanks to an adjustable palm rest

AmaPilot⁺ multi-function joystick – Many functions in one hand

"Get in and drive off" is the motto! Drive the machine steplessly and intuitively using the AmaPilot⁺ multi-function joystick. In cruise control, and with the maximum forward position of the multi-function joystick, the Pantera achieves speeds of up to 50 km/h on the road and the pre-selected desired operating speed in the field (the permissible maximum speed may vary depending on the national road traffic regulations).

If you pull the driving lever back, the hydrostatic brake is automatically applied. This automatically actuated hydraulic brake assists the driver in all situations. The highest sensitivity on start-up and when manoeuvring is guaranteed.

All functions of the sprayer can also be controlled via the multi-function joystick. In this way, you can use AmaPilot⁺ for all the functions of steering management, part-width section and boom control and additional functions such as end nozzle control as well as the +/- application rate button.

Advantages of AmaPilot⁺:

- ✔ Perfect ergonomics
- ✔ Almost all the functions directly to hand via the 3 levels
- ✔ Adjustable palm rest
- ✔ Freely programmable individual key layout

Camera systems

The image from the optional reversing camera, which provides a view to the rear or of the manoeuvring device, is fully integrated in the AmaDrive 7.0 vehicle terminal. The display is automatically activated when reverse gear is engaged.

A second optional camera system with a separate screen can be used to permanently display the image from a camera pointed at the right front wheel.



Reversing camera on the rear of the Pantera

- ✔ Large 135° viewing angle
- ✔ Camera with heating and lotus coating
- ✔ Clear picture even after dark thanks to infrared night vision technology
- ✔ Automatic back light function



Pantera 7004 self-propelled sprayer

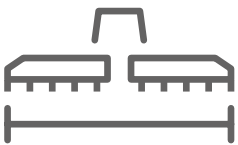

24 m – 48 m



6,600 l



up to 96 part-width
sections



610 l/min
pump capacity

The advantages at a glance:

- ⊕ High tank capacity and wide boom widths at a working speed of up to 30 km/h
- ⊕ Lightweight design and large tyre sizes with optimum weight distribution
- ⊕ Compact design and minimal turning circle for high efficiency in smaller fields
- ⊕ Ultra-modern chassis and cab technology as well as user-friendly operation
- ⊕ Hydraulic track width adjustment and a wide variety of booms for many different areas of application
- ⊕ Low centre of gravity and highly-stable running gear with automatic slope compensation



MORE INFORMATION

www.amazone.net/pantera



PRODUCT FILM
Find out more



DOWNLOADS
mySprayer App



SMARTLEARNING
www.amazone.net/smartlearning

Standard equipment for the Pantera 7004

- ✔ Hydro-pneumatic running gear with independent trailing arm suspension with automatic level regulation and adaptive, forward-speed related suspension control
- ✔ Track widths from 2.00 m to 3.00 m (will differ depending on the chassis type and tyres); the track width can be adjusted steplessly from the AmaDrive vehicle terminal
- ✔ Hydraulic front-wheel steering, all-wheel steering and dog-leg steering; steering angles tailored to the speed and operation
- ✔ Active slope compensation for more comfort and safety
- ✔ Headland management with automated switch from front-wheel to all-wheel steering, boom lift with AutoLift
- ✔ Forward speeds up to 50 km/h, infinitely variable hydro-static single range transmission with traction control
- ✔ Hydraulic braking system with disc brakes and hydraulic parking brake
- ✔ 6 cyl. Deutz turbodiesel engine, Common-Rail injection technology, maximum power 225 kW (306 hp) according to ISO 14396, Stage 3A or Stage 5 exhaust emissions compliant



- ✔ Wheels with a height of up to 2.05 m for optimum soil protection



- ✔ ECO-Mode: fuel saving, performance-related engine rev regulation on the road and in the field
- ✔ 290 l or 400 l fuel tank: Stage 5 exhaust emission compliant with 20 l DEF tank (Diesel Exhaust Fluid, e.g. AdBlue)
- ✔ Claas Vista cab, climate control, heating, air-suspended comfort seat, adjustable steering column, radio with USB SD slot, Bluetooth hands-free phone connectivity, windscreen and rear window sunblinds
- ✔ AmaDrive vehicle terminal with colour touchscreen (7") for vehicle operation
- ✔ The comfortable armrest, with the AmaPilot⁺ multi-function joystick for drive control and sprayer operation, was developed in-house
- ✔ Side lights, dip and main beam headlights, 12 front work lights and 2 side view work lights in the cab roof, front illumination of the boom as well as illumination of the operator station.
- ✔ 6,600 l spray agent tank with agitator, fill level indicator, tank cleaning nozzles; 500 l fresh water tank and induction bowl
- ✔ 610 l/min pump capacity with 3" suction port, max. suction capacity 750 l/min via the venturi
- ✔ Pump speed set from the terminal and remote control of the pump down at the operator station.
- ✔ Suction valve with 3" suction filter (32 mesh) and fill port for fresh water tank
- ✔ Valve chest, self-cleaning 1 1/4" pressure filter (50 mesh) and part-width section control, quick emptying
- ✔ Comfort-Pack with digital external fill level indicator, automatic fill stop, fill-level dependent and auto-dynamic agitation regulation and remote-controlled cleaning from the cab
- ✔ Super-light and super-stable Super-L boom



Experts and designers from all over the world were impressed and delighted with the combination of form and performance.



reddot winner 2023

Pantera 7004 and Pantera 7004-W

Intelligent chassis management

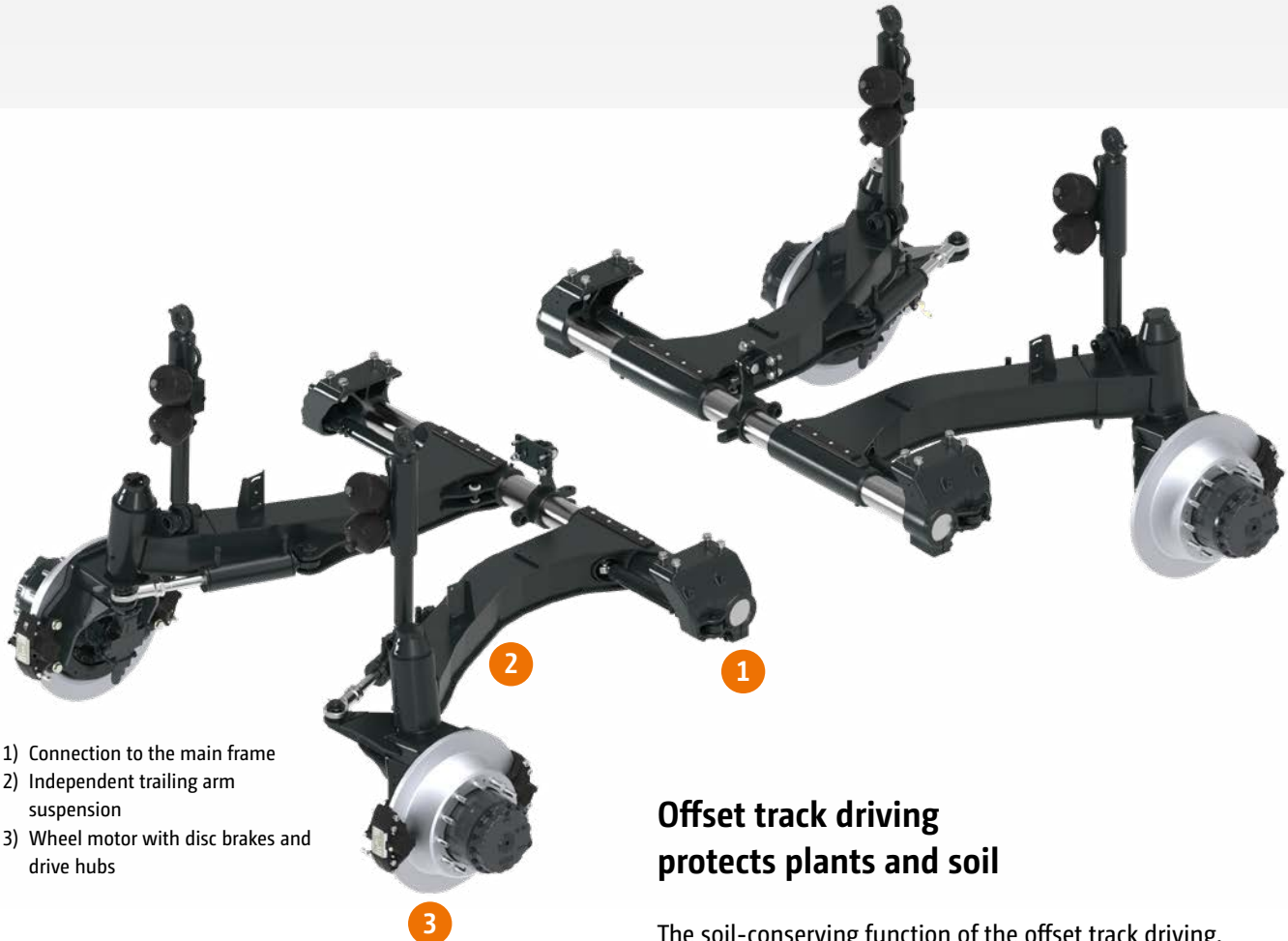

The advantages of the chassis with independent wheel suspension with slope compensation:

- ✔ Independent suspension with perfect contour following
- ✔ Comfortable and safe driving characteristics in any situation thanks to adaptive chassis control
- ✔ Hydro-pneumatic suspension system with level regulation
- ✔ Super-robust frame
- ✔ Reliable hydraulic system – no air regulation
- ✔ Stepless track width adjustment
- ✔ High ground clearance
- ✔ Headland management for steering and boom functions
- ✔ Stress relief for the driver and gentle boom treatment
- ✔ Offset track driving for maximum soil protection
- ✔ Safe driving on slopes via the automatic slope compensation

Offset track driving protects plants and soil

The soil-conserving function of the offset track driving, in which, for example, the front wheels can be set at the minimum track width and the rear wheels at maximum, ensures that the soil is travelled over just once. As a result, especially in unfavourable soil conditions, the soil is not smeared as much and young plants suffer hardly any damage. In contrast to dog-leg steering, the machine is always aligned to the direction of travel.

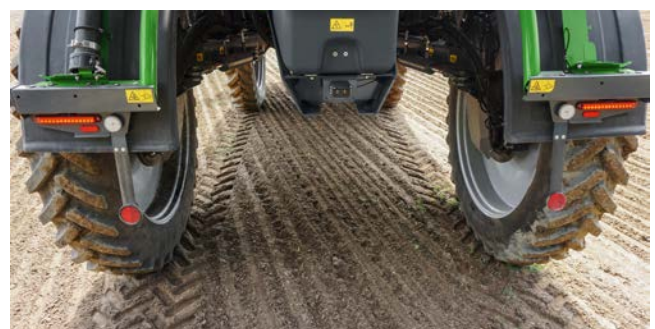

Offset track driving protects plants and soil



Pantera 7004

Pantera 7004-W

Pantera 7004 – The optimum chassis for all requirements

The new running gear with independent trailing arm suspension is of a unique design. The hydro-pneumatic suspension is adaptive, whereby the characteristics of the running gear are tailored to suit the driving situation. This intelligent control provides the best driving stability and maximum driving comfort combined with a simple and weight-reduced design in comparison with a conventional independent suspension. In addition, the system prevents any rocking when the tank is not completely full which enables high driving speeds, even on poor quality roads.

Optimum weight distribution

Hydraulic track width adjustment, with a standard track width from 2.00 m to 2.75 m, is fitted as standard. The Pantera-W, with track widths from 2.25 m to 3.00 m, is also available. The ground clearance in both machines is approximately 1.30 m, which means that tall crops can be driven through without damage.

Active slope compensation

The integrated slope compensation is another highlight. The inclination of the vehicle is detected via sensors and the machine is automatically kept horizontal up to a gradient of 10 %. In combination with the low centre of gravity of the machine and the hydro-pneumatic chassis, this feature provides extremely high slope stability. In addition to the enhanced driving comfort, this enables the driver to work extremely safely, even in very hilly terrain.



Low risk of tipping over in hilly terrain thanks to automatic slope compensation

Drive management with optimised fuel efficiency

Pantera – high-powered intelligence

Stage 5 emissions compliant engine

The new Stage 5 emission compliant engine from AMAZONE uses exhaust gas recirculation, a diesel oxidation catalyst and a diesel particle filter to help protect the environment. The diesel particulate filter is continuously regenerating during operation. The SCR catalytic converter reduces the levels of nitrogen oxide with the aid of a diesel exhaust fluid (DEF) injection. The 20 litre DEF tank is positioned at the side of the standard 290 litre diesel tank. The DEF consumption amounts to approximately 2.5% of the fuel consumption. A tank extension of 110 litres is available as an option, meaning that a tank capacity of 400 litres is possible.

The benefits:

- ✔ Stepless hydrostatic drive from 0 to 50 km/h*
- ✔ State-of-the-art fuel management on the road and in the field with ECO and POWER mode
- ✔ Tailor-made speed regulated radiator fan drive
- ✔ Proven Deutz technology with a comprehensive service network

The heart as a unit: engine and hydrostatic drive

Deutz 6-cylinder diesel engine with a maximum output of 225 kW (306 hp)

- ✔ Turbocharger with intercooler
- ✔ Common-Rail injection technology
- ✔ 7.8 litre capacity
- ✔ Country-specific execution according to either Stage 3A or Stage 5 emission compliance

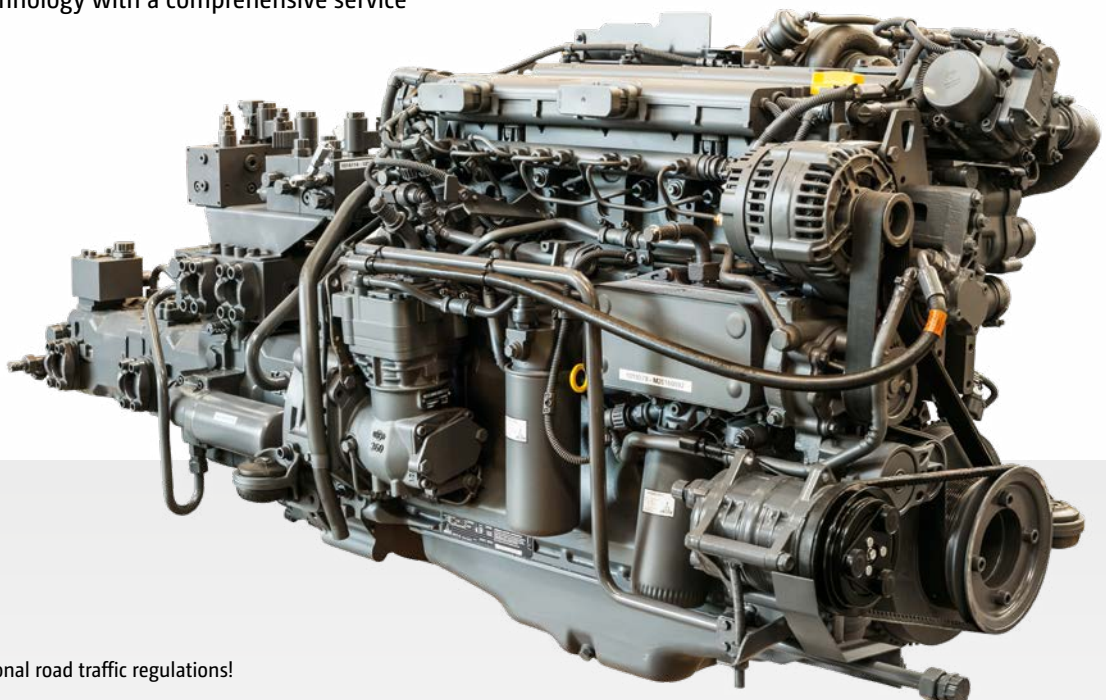

* Please be aware of national road traffic regulations!

The benefits of the clever cooling system:

- ✔ Revs on demand
- ✔ The fans even switch off under low power demands and cool temperatures
- ✔ Positioned beyond the reach of any dirt. Left charge air, hydraulics. Right engine, air-conditioning

**Running at optimum fuel saving: ECO or POWER**

The new and optimised engine rev regulation mean that you can always operate the Pantera at the optimum fuel consumption efficiency.

When ECO Mode has been selected in the AmaDrive vehicle terminal, the engine will search for the optimal operating point for torque and revs in the given driving situation.

When spraying on the flat, an engine rev reduction down to 950 rpm is possible. This finely tuned, automatic adaptation of engine speed takes place continuously between 950 and 2,000 rpm.

However, when working on steep slopes, or operating with a full tank in hilly terrain, maximum power at up to 2,000 rpm can be drawn upon by using the POWER Mode.

Example in ECO mode

- 1) **Around 80 kW is required on the flat**
- 2) **When the machine is climbing a hill, the torque increases under load.** The speed remains constant.
- 3) **The climb is harder: the power consumption increases to 120 kW.** The speed remains constant with slightly increased fuel consumption.

Infinitely variable power

The powerful Deutz 6-cylinder diesel engine with Common-Rail injection technology provides 306 hp and impresses by its high performance yet low fuel consumption. Thanks to the modern hydrostatic drive mechanism, you can drive the Pantera with absolute infinite variability.

This system allows, even at a low engine speeds, high start-up torques and a very dynamic acceleration.

Good power/weight ratio

The low unladen weight of the Pantera 7004 (approx. 11,750 kg in a 24 metre boom width) is another advantage with regard to its low fuel consumption. The fuel tank volume of up to 400 litres enables high work rates over long days.



- ✔ Integrated DEF tank for the Pantera with its Stage 5 emission compliant engine

Drive and brake management

Your safety is paramount!



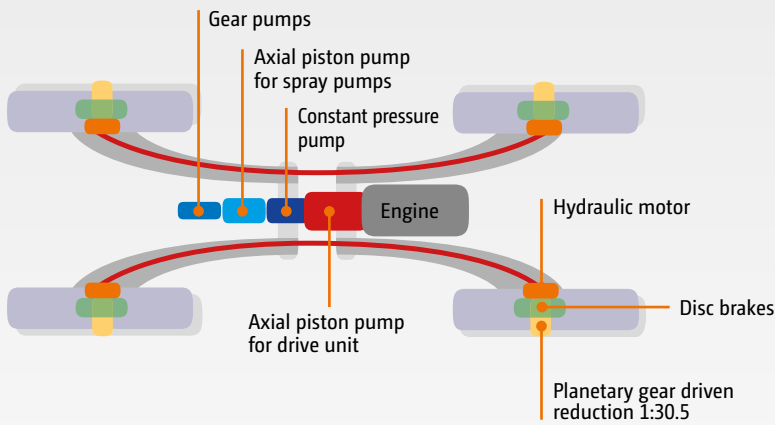

Pantera – reliable intelligence

Due to the large wheel diameter, particularly high torques are necessary when starting off. The intelligent drive concept of the Pantera does not build up these high forces hydraulically but mechanically via the fixed reduction ratio of the planetary gearbox. This is an extremely reliable drive under difficult ground conditions and when starting off.

The tyres with a height of up to 2.05 m provide maximum traction and soil protection. The higher gear reduction ratio in the Pantera 7004 also ensures that enough torque is available in any driving situation.

Traction control as standard

The drive torque of the four wheel motors is constantly being monitored electronically and then regulated to ensure the optimum vehicle behaviour even under difficult conditions. Power-consuming differential locks are avoided. Traction control (TCS) also ensures safe driving on the road at all times.

Pantera – safe intelligence

When the speed is reduced via the drive lever, the Pantera's hydrostatic brake is activated and the vehicle is braked down to a complete stop without fuss. In addition, the Pantera has a hydraulic braking system with disc brakes, which are applied via a foot pedal. The drive stops automatically when they are applied.

Advantages of the drive system:

- ✔ High torque at all times
- ✔ No speed change steps
- ✔ Possibility of larger wheel diameters
- ✔ A fixed reduction ratio in the planetary gearbox drives the wheel

Advantages of the braking system:

- ✔ Safe and elegant driving performance
- ✔ Reliable braking performance, even during emergency stops from 50 km/h
- ✔ Automatic activation of the parking brake when standing still
- ✔ Autohold assist when starting off on a slope

Cab management

A professional working environment – get on board and off you go!



Relax ...

... when you sit in this cab

Advantages of the cab:

- ✔ Good all-round visibility
- ✔ Superb sound insulation
- ✔ Convenient, wide access with hydraulically folding ladder
- ✔ Individually adjustable air-suspended comfort driver seat with leather option, seat ventilation and seat heating
- ✔ Large folding passenger seat
- ✔ Adjustable steering column
- ✔ Optional footrests
- ✔ Height and longitudinally adjustable arm rest with integrated controls
- ✔ Climate control
- ✔ Active carbon filters or optional Category 4 cab air filtration system
- ✔ Electrically adjustable and heated exterior mirrors
- ✔ Additional mirror for best view of the front wheel
- ✔ Document compartment
- ✔ Large cool box under the passenger seat
- ✔ Radio with USB SD slot, Bluetooth hands-free connectivity
- ✔ Sun blinds for front and rear windscreens

By day and night – illumination for long and safe working days

14 LED work lights are now incorporated in the cab roof as standard. Night turns to day in conjunction with the LED work lights at the rear of the machine and the option of individual nozzle lighting on the boom.

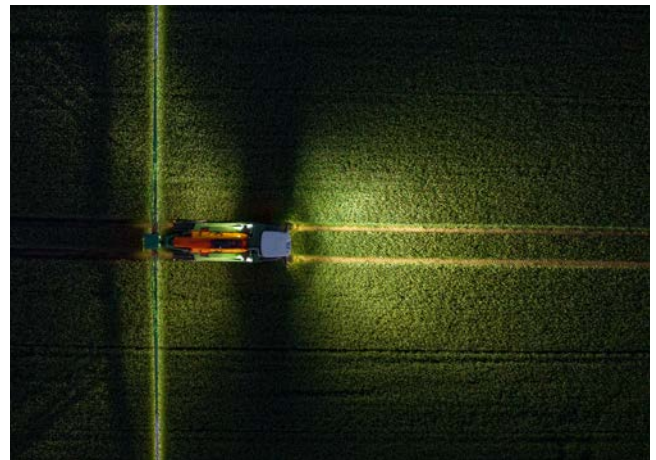

Everything safely stowed!

The storage compartment under the cab offers sufficient space for convenient storage of, for instance, spray agent canisters.

A tool box is located under the steps to the cab.



✔ Standard LED rear lights



✔ Convenient and large – compartment for such as spray canisters



✔ Tool box under the cab

Operation management

Everything under control, everything in view

Twin terminal solution for comfortable operation

ISOBUS terminal for operation of the sprayer

The TopCon X35 operator terminal with a 12.1" display and the AmaTron 4 operator terminal with an 8" display are offered for ISOBUS control. Both terminals have a multi-touch colour display. The practical MiniView layout means that handling is extremely comfortable and meets the highest demands of Precision Farming. The sprayer can be conveniently operated via the freely programmable AmaPilot⁺ multi-function joystick.

AmaDrive 7.0 vehicle terminal

The new AmaDrive 7.0 vehicle terminal is integrated in the ergonomic armrest. All machine-specific functions can be clearly displayed and intuitively operated on the colour 7" touchscreen. This is provided by the self-explanatory operating structure without multi-level sub-menus, which can be used to control the most important settings from the main screen. The freely configurable status bar means that particularly relevant information is always in view. Switching between day and night mode also makes operation easier.



Twin-terminal solution with the TopCon X35 ISOBUS terminal and AmaDrive 7.0 vehicle terminal as well as the AmaPilot⁺ multi-function joystick

Control the following functions

with the AmaDrive 7.0 vehicle terminal:

- ✔ Cruise control
- ✔ Engine management with ECO or POWER mode
- ✔ Steering and headland management
- ✔ Track width adjustment
- ✔ Vehicle lighting
- ✔ Control of the central lubrication system

Display of:

- ✔ Forward speed and engine revs
- ✔ Fuel tank level and engine temperature
- ✔ Diagnostic data of engine and hydraulic system
- ✔ Field and road modes

- ✔ The new armrest was developed in-house and is characterised by its extremely clear and ergonomic design. It is tailored specifically to the functionality of a self-propelled sprayer, and all the important functions are always within reach.



Perfect ergonomics for the driver

AmaPilot⁺ multi-function joystick – Many functions in one hand

"Get in and drive off" is the motto! Drive the machine steplessly and intuitively using the AmaPilot⁺ multi-function joystick. In cruise control, and with the maximum forward position of the multi-function joystick, the Pantera achieves speeds of up to 50 km/h on the road and the pre-selected desired operating speed in the field (the permissible maximum speed may vary depending on the national road traffic regulations).

If you pull the driving lever back, the hydrostatic brake is automatically applied. This automatically actuated hydraulic brake assists the driver in all situations. The highest sensitivity on start-up and when manoeuvring is guaranteed.

All functions of the sprayer can also be controlled via the multi-function joystick. In this way, you can use AmaPilot⁺ for all the functions of steering management, part-width section and boom control and additional functions such as end nozzle control as well as the +/- application rate button.

Advantages of AmaPilot⁺:

- ✔ Perfect ergonomics
- ✔ Almost all the functions directly to hand via the 3 levels
- ✔ Adjustable palm rest
- ✔ Freely programmable individual key layout

Camera systems

The image from the optional reversing camera, which provides a view to the rear or of the manoeuvring device, is fully integrated in the AmaDrive 7.0 vehicle terminal. The display is automatically activated when reverse gear is engaged.

A second optional camera system with a separate screen can be used to permanently display the image from a camera pointed at the right front wheel.



Reversing camera on the rear of the Pantera

- ✔ Large 135° viewing angle
- ✔ Camera with heating and lotus coating
- ✔ Clear picture even after dark thanks to infrared night vision technology
- ✔ Automatic back light function



AmaTron Connect

New ways of comfortable networked operation

With AmaTron Connect, AMAZONE provides a digital interface to a smartphone or tablet. The mobile device and AmaTron 4 are simply connected as a hotspot. AmaTron Connect enables use of the AmaTron Twin App as well as data exchange via agrirouter and the myAmaRouter App.



Everything in view at all times with the AmaTron Twin App and the holder kit for a tablet for rigid mounting on the AmaTron 4

AmaTron Twin App

Clear display enhancement

The AmaTron Twin App offers the driver even more comfort during work, as any GPS functions in the map view can also be operated via a mobile device, e.g. a tablet, in parallel with machine operation on the AmaTron 4.

Advantages of the AmaTron Twin display enhancement:

- ✔ Use of an existing mobile device
- ✔ Greater clarity – all applications in sight
- ✔ Comfortable control of the GPS functions in the map view, in parallel, via the mobile device
- ✔ Clear, authentic representation of the working machine and its part-width sections

Now download the free App and try the DEMO in the App.



Alternative map views with AmaTron Twin – clear display of the machine and its part-width sections, as well as buttons on the right hand side of the mobile device.

agrirouter –

the independent data exchange platform for agriculture



Watch the video for more details

Secure data exchange

agrirouter is an independent data exchange platform for farmers and contractors. It enables simple and cross-manufacturer data exchange between machines and agricultural software applications, thereby reducing administration. The user retains full control over the data at all times.

myAmaRouter App

For the on-line transfer of data between AmaTron 4 and agrirouter

The myAmaRouter App enables data to be exchanged between the AmaTron 4 ISOBUS operator terminal and the agrirouter manufacturer-independent data exchange platform. If an AMAZONE machine is to be used to carry out a task with job data (e.g. application maps), the data can be easily transmitted from a Farm Management Information System (FMIS) to AmaTron 4 via agrirouter and the myAmaRouter App. After the work has been completed, the job can be sent back and is available for documentation in an agricultural software application.

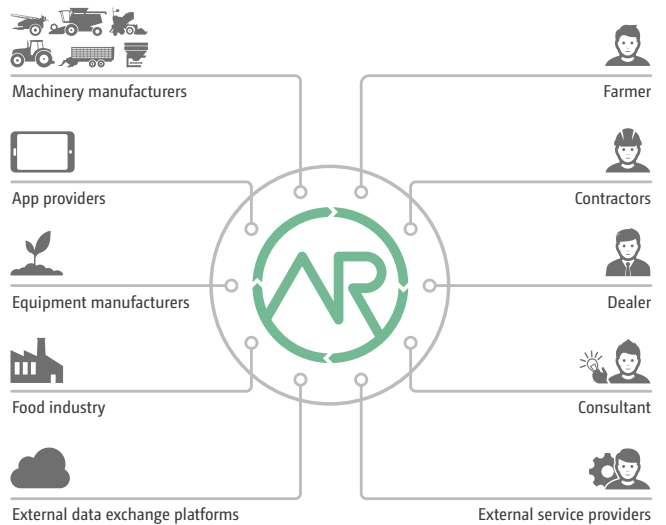

The manufacturer-independent agrirouter enables secure and uncomplicated data exchange.

Benefits of agrirouter:

- ✔ Simple data exchange between the AmaTron 4 ISOBUS operator terminal and the manufacturer-independent agrirouter data exchange platform
- ✔ Easy and rapid transfer of job and task data without the need for a USB stick
- ✔ More flexibility in data exchange and documentation

Uncomplicated data transfer. Transparent and secure!



Automatic part-width section control GPS-Switch with Section Control

GPS-Switch

If the operating terminal facilitates Section Control, such as GPS-Switch part-width section control from AMAZONE, the part-width sections are activated completely automatically and in relation to the GPS position. Once a field has been created, and then in automatic mode, the driver can concentrate fully on the operation of the towing vehicle, since the part-width sections are switched automatically in wedge shaped fields and on headlands.

Benefits of automatic part-width section control:

- ✔ Stress relief on the driver
- ✔ Increase in precision especially at night or at higher speeds
- ✔ Fewer overlaps and gaps
- ✔ Saving on input costs
- ✔ Less crop damage and less environmental pollution

❗ "With Section Control, the ISOBUS terminal takes a lot of pressure away from the driver."

("dlz agrar magazine" – test report ZA-TS fertiliser spreader · 02/2017)

With GPS-Switch, AMAZONE offers GPS-based, fully automatic part-width section control for all AMAZONE operator terminals and ISOBUS-compatible fertiliser spreaders, crop protection sprayers or seed drills.

GPS-Switch basic

- ✔ Automatic part-width section control with up to 16 part-width sections
- ✔ Creation of a virtual headland
- ✔ Automated boom lowering on AMAZONE crop protection sprayers
- ✔ Optional with AmaTron 4

GPS-Switch pro (as an extension of GPS-Switch basic)

- ✔ Automatic part-width section control with up to 128 part-width sections, in particular for crop protection sprayers with individual nozzle control
- ✔ Marking obstacles (e.g. water holes, pylons)
- ✔ Auto-zoom when approaching the headland
- ✔ Optional with AmaTron 4

Overlaps on the headland or in wedge shaped fields are prevented via precise switch points with GPS-Switch.



Example: 24 m boom width (6-6-8-8-8-6-6 = 48 nozzles)

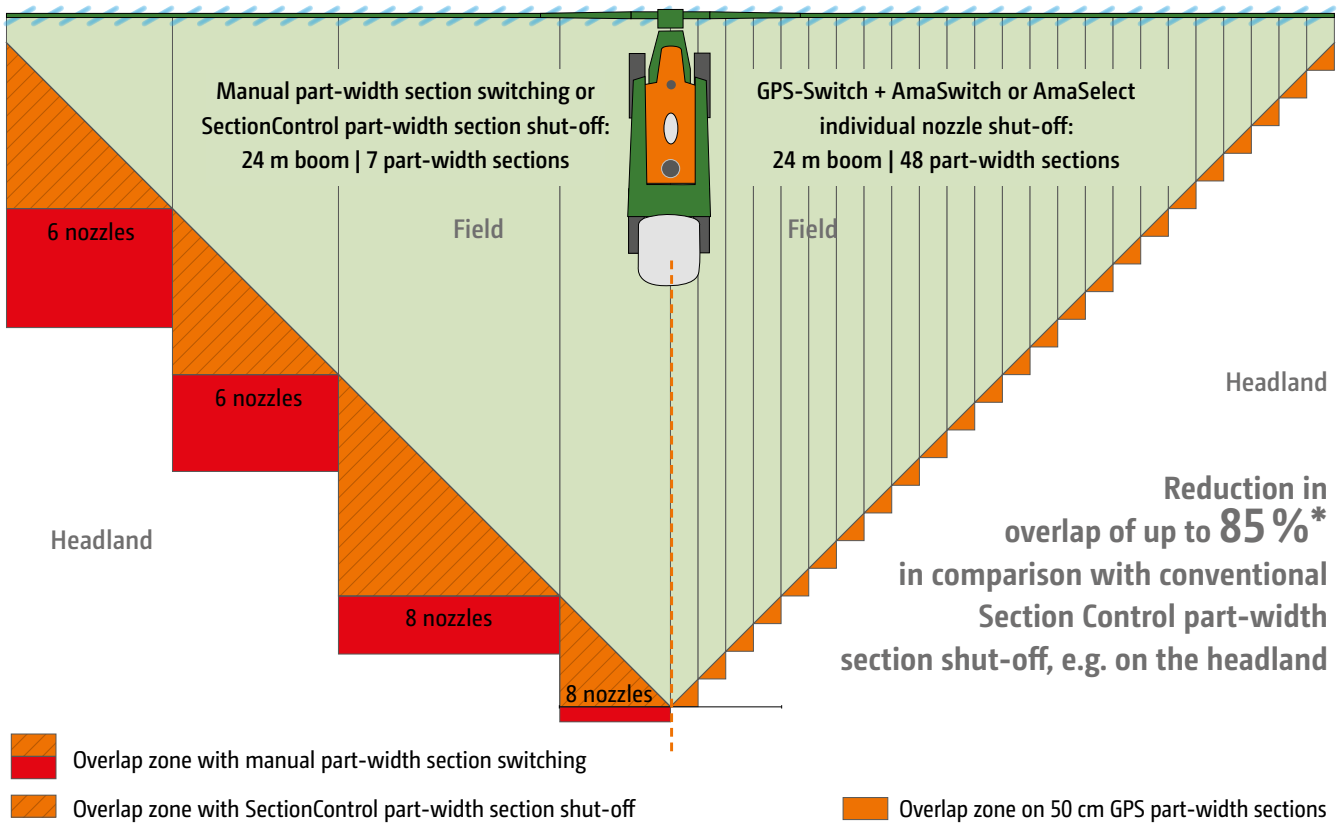

Automatic part-width shut-off on the headland and in wedge-shaped fields **GPS-Switch**

5%*

Saving on crop protection agent usage



Electric individual nozzle control **AmaSwitch or AmaSelect**

5%*

Additional saving in crop protection agent usage

* Savings are dependent on field shape, boom width and the number of part-width sections

Precise switching with 50 cm part-width sections

The decisive benefit of individual nozzle control is the possibility to operate with small part-width sections giving an even greater degree of accuracy in wedge shaped fields, short work and on the headland. The automatic switching of individual nozzles on 50 cm part-width sections is made possible by combining AmaSwitch or AmaSelect and the automatic GPS-Switch part-width section control.

Overlapping is reduced by up to 85% in comparison with conventional Section Control part-width section shut-off. So, the combination of GPS-Switch and individual nozzle control results in, depending on field shape and size, the working width and number of part-width sections, significant savings in spray agent compared with a normal spraying system used thus far.

Workday made easy –

Make the most of the possibilities!

GPS-Maps&Doc

All standard ISOBUS terminals from AMAZONE can collect and save machine and site-specific data using Task Controller. Part-area, site-specific operation via application maps in either Shape file or ISO-XML formats is also possible.

- ✔ Easy creation, loading and processing of jobs
- ✔ Start a new task straight away and decide later whether the data is to be saved or not
- ✔ Import and export of jobs in ISO-XML format
- ✔ Job summary via PDF export
- ✔ Intuitive system for running application maps in Shape file or ISO-XML formats
- ✔ Automatic part-area, site specific regulation of the application rate
- ✔ Indication of inactive field boundaries and automatic field detection when approaching the vicinity
- ✔ Optimum crop management using need-oriented application
- ✔ Equipped as standard for AmaTron 4

GPS-Track

The GPS-Track parallel guidance greatly helps with orientation in the field, especially on grassland or in areas without tramlines.

- ✔ With a virtual light bar in the status bar
- ✔ Automatic tramline control via GPS for seed drills
- ✔ Various track modes such as A-B lines or contour driving
- ✔ Optional with AmaTron 4

AmaCam

Software licence for displaying a camera image on AmaTron 4.

- ✔ Automatic display of the camera image on AmaTron 4 when reversing



Display of the application map in AmaTron 4



Display of the camera image in AmaTron 4

Automated steering systems

Automated steering systems

AMAZONE offers the Steer-Ready kit as a GPS-based automated steering solution which controls the hydraulic steering. This provides a reproducible track-to-track accuracy of approx. 2 cm in combination with an RTK correction signal.

Steer Ready prepared connection for third-party systems

As an option, the Pantera can be equipped with the Steer Ready prepared connection for automatic steering systems. As a result, the Pantera is prepared ex works for the installation of various steering system products.

Two versions ex works

There is a choice of two manufacturers with regard to the steering system which can be installed in the Pantera in the factory. The customer can choose between the premium suppliers TopCon and Trimble, each of which can be equipped with different correction signals up to and including RTK accuracy, depending on the requirements.



TopCon X35ISOBUS terminal with AGS-2 receiver for automatic track guidance and part-width section control



Trimble TME 1260 ISOBUS terminal with NAV-900 receiver for automatic track guidance and part-width section control

Steering management for all Panteras

It has to be manoeuvrable, compact and flexible!



Front-wheel steering



All-wheel steering



Dog leg steer

Relax and enjoy the job – Even on the headland

In spite of the size of the vehicle, the minimum turning circle of the Pantera is only 4.50 m when in all-wheel steer. This extreme manoeuvrability significantly increases work rates, particularly in small fields. Switching between all-wheel and front-wheel steering is carried out via the AmaDrive 7.0 vehicle terminal. Dog leg steer helps you keep perfectly on track, even on a side slope.

The Pantera also shows its intelligence on the headland: If headland management has been activated on the AmaDrive 7.0 vehicle terminal, switching off the nozzles automatically switches to all-wheel steering and the boom is lifted. Front-wheel steering is restored when the nozzles are switched on after turning has been completed.

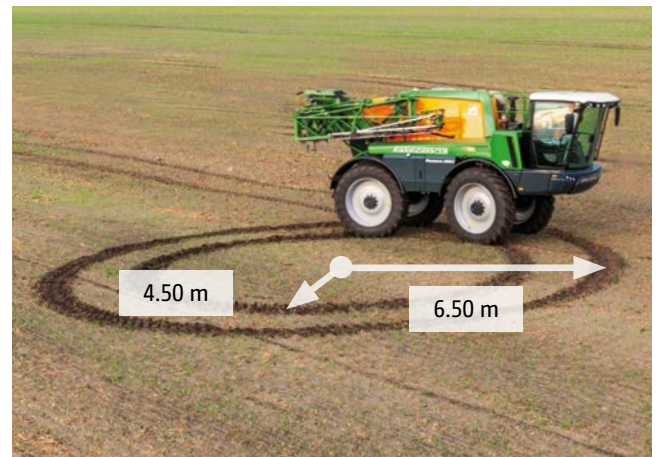

AmaDrive 7.0 vehicle terminal

Intelligent liquid management: integrated into the total machine concept

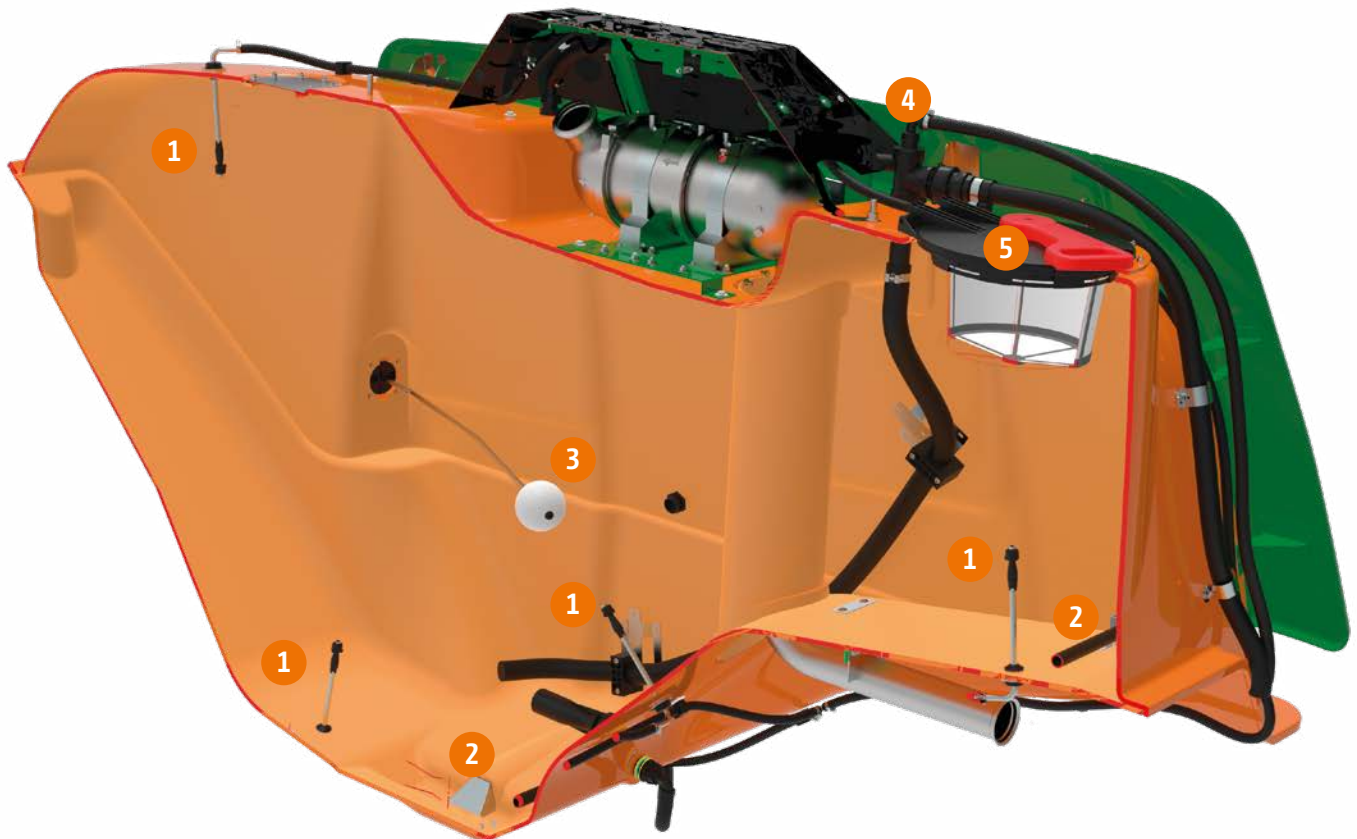

- 1) High-pressure nozzles
- 2) Agitator
- 3) Fill level sensor

- 4) Power Injector
- 5) Tank lid

Optimised for professional use

The spray agent tank with a capacity of 4,500 litres (actual capacity 4,750 litres) or 6,600 litres (actual capacity 7,000 litres) is positioned low in the frame and ensures a favourable centre of gravity and an even weight distribution across all four wheels of the Pantera. The spray agent tank consists of high grade glass fibre reinforced plastic with smooth internal and external walls.

The low positioned outlet sump ensures the smallest of residual volumes even in sloping terrain. Electronic fill level indication and four rotating high-pressure nozzles for internal cleaning are standard. The 500 litre fresh water tank with fill level indicator is located at the rear of the Pantera.



Pump system on the right-hand side of the machine

High-capacity pumps

The two high-capacity piston diaphragm pumps with a pump capacity of 520 l/min for the Pantera 4504 or 610 l/min for the Pantera 7004 ensure that spraying is possible at high water rates and high forward speeds but sufficient agitation capacity is always available. The pump speed from 380 to 580 rpm can be selected via AmaDrive. The pumps are positioned on the right-hand side of the machine and are easily accessible.

Bowser fill connection with automatic fill stop

The automatic fill stop prevents overfilling of the machine when filling via the suction hose. Automatic fill stop is optionally available for the bowser fill port. The bowser fill port is located up front in the storage compartment, which allows pressure filling from the edge of the field without having to fold in the boom. The 3" port in the Pantera 7004 enables filling to be carried out at up to 1000 l/min.



- ✔ Bowser fill port in the storage compartment with automatic fill stop

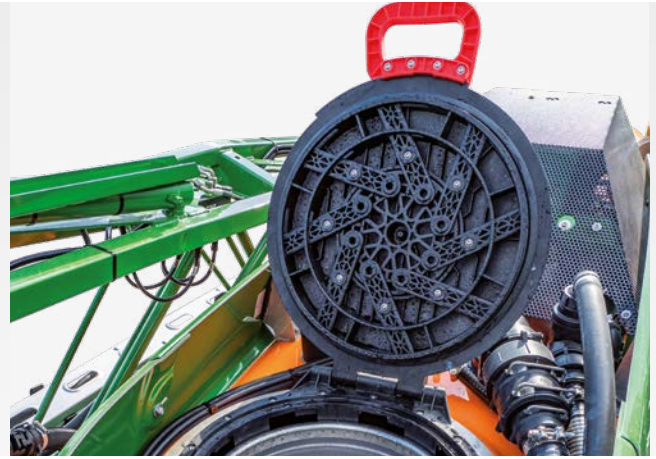

Securely closing tank dome cover

Tank dome cover

The tank dome cover is completely developed and manufactured by AMAZONE and is unique on the market. The ergonomic handle makes it simple to open and close with little effort. The tank dome lid is robustly designed and optimally closed by the 8-fold locking system.

High application rates thanks to HighFlow⁺

HighFlow⁺ allows both pumps to be used for spraying. If the normal spray output of 200 l/min is not sufficient, the liquid flow from the agitation pump is automatically used as required until the desired application rate is reached.

The remaining capacity of the agitation pump continues to be used for agitating the liquid in the spray agent tank.

- ✔ It allows large quantities of liquid fertiliser to be applied at higher speeds.
- ✔ For vegetable applications, then rates of 2,000 l/ha at 5 -6 km/h are possible.



- ✔ HighFlow⁺ is equipped with an additional, self-cleaning pressure filter

SmartCenter with Comfort-Pack

Handling made easy

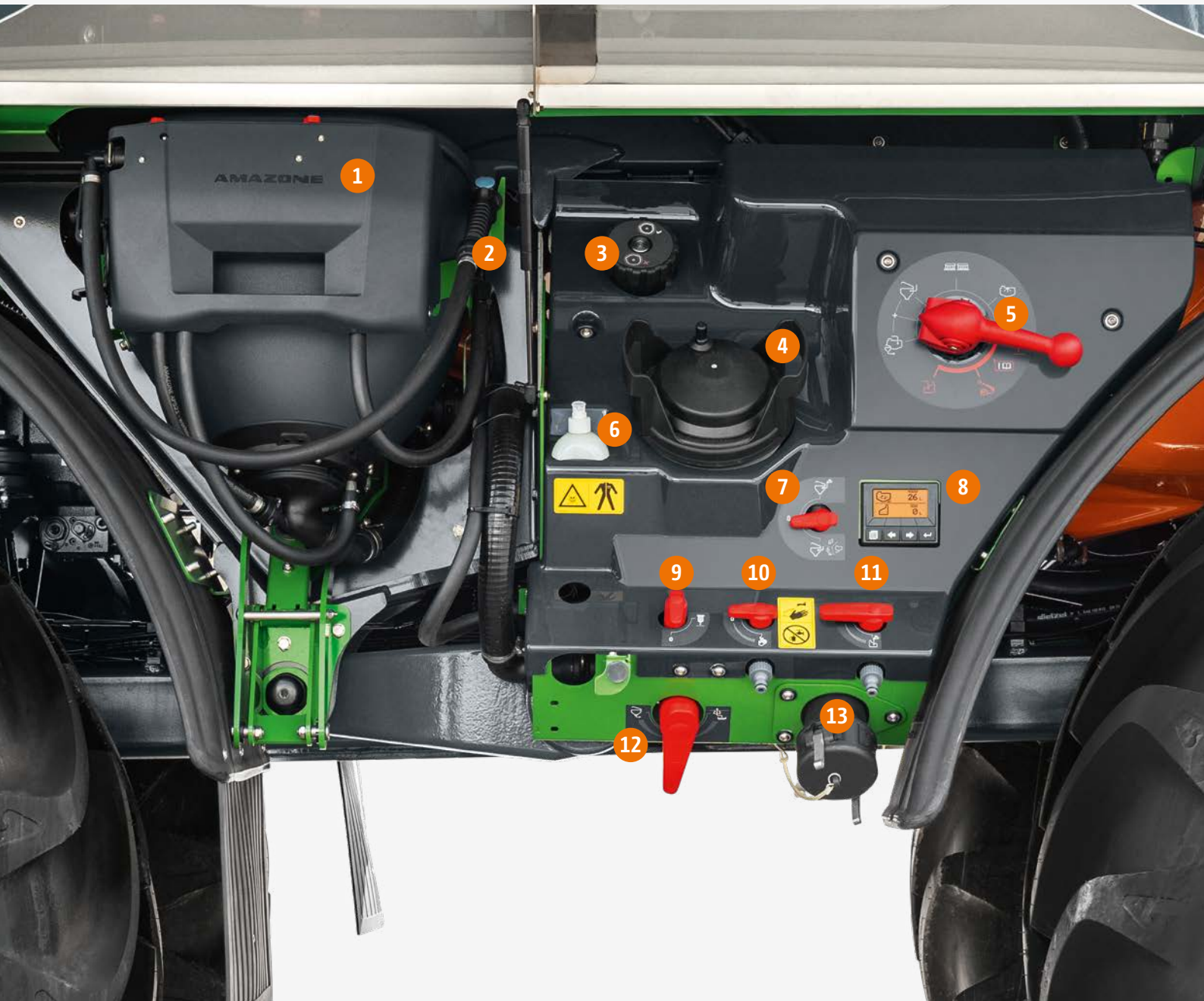

The operating components of the Pantera with Comfort-Pack

- | | | |
|---|-----------------------------------|---|
| 1) Induction bowl | 6) Soap dispenser | 11) Fill port for fresh water tank including Gardena coupling |
| 2) Hand lance pistol for rinsing out the induction bowl | 7) Control tap for induction bowl | 12) Control tap for venturi/induction bowl draw-out/additional filling capacity |
| 3) Self-cleaning pressure filter | 8) TwinTerminal 3.0 | 13) 3" Camlock suction port |
| 4) Suction filter | 9) Pressure filter drain | |
| 5) 7-way pressure tap | 10) Hand wash tank tap | |



Comfort-Pack with TwinTerminal 3.0

Comfort-Pack – Simple and intuitive operation

In conjunction with Comfort-Pack, the TwinTerminal 3.0 is also utilised. In addition, automatic fill stop for the suction fill is also included. As an option, fill stop is also available when pressure filling from a bowser. During application, the intensity of the agitation is regulated depending on the tank fill level. As the fill level decreases, the agitation capacity is automatically reduced down until it is completely switched off preventing the formation of foam at a low fill level. In addition, the automatic agitation regulation offers auto-dynamic agitator control. This means: the auxiliary agitator is closed when a higher application rate is required at the boom.

After the spraying operation is finished, Comfort-Pack provides fully automatic cleaning which can be controlled completely remotely from the cab. Additional functions such as boom rinsing, cleaning the spray liquid circuit from heavy deposits or a defined dilution of a subsequent tank mix in the field are all functions included within Comfort-Pack.

The benefits:

- ✔ Comfortable filling of the spray agent and fresh water tanks via the automatic fill stop
- ✔ No foaming of the spray agent due to the automatic fill-level dependent control and switching off of the agitator
- ✔ Always maximum capacity when spraying and agitating thanks to the auto-dynamic agitator control
- ✔ Remote-controlled, automatic cleaning programmes for complete sprayer wash-out



In-house developed 7-way pressure tap

7-way pressure tap – safe changeover with cam and seat valves

The 7-way pressure tap provided in the Pantera with Comfort-Pack is extremely practical. As opposed to a normal pressure tap, the in-house developed valve from AMAZONE consists of a cam and seat valves. Exclusively by swivelling in and out the handle on the pressure tap, the relevant liquid paths are reliably opened or closed.

The benefits:

- ✔ All functions on the pressure side are actuated via a tap
- ✔ Minimal wear of the seals and insensitivity to sand and suspended matter in the water
- ✔ No unwanted route is activated when changing the function

SmartCenter with Comfort-Pack plus

Operation with maximum comfort



The operating components of the Pantera with Comfort-Pack plus

- | | | |
|---|-----------------------------------|---|
| 1) Induction bowl | 5) Self-cleaning pressure filter | 10) Fill port for fresh water tank including Gardena coupling |
| 2) Hand lance pistol for rinsing out the induction bowl | 6) TwinTerminal 7.0 | 11) Closed Transfer System, pressure connection 1" |
| 3) Closed Transfer System, pressure connection ¾" | 7) Soap dispenser | 12) 3" Camlock suction port |
| 4) Suction filter | 8) Control tap for induction bowl | |
| | 9) Hand wash tank tap | |



TwinTerminal 7.0 can be operated in gloves without any problems

TwinTerminal 7.0 with pressure-sensitive touchscreen

Handling is made especially comfortable by Comfort-Pack plus. Instead of operating taps, TwinTerminal 7.0 makes machine operation much easier with its pressure-sensitive touchscreen. The complete control of the spray agent circuit is carried out solely via the pressure-sensitive touch screen which functions perfectly even when wearing gloves. The user just selects the desired function and the sprayer adjusts itself automatically!

In the job computer, two individual filling profiles for different operators or applications can be stored. Then only the hose has to be coupled for filling, and the machine automatically fills the spray agent tank and fresh water tank up to the desired tank fill level. As an option, the operator can select individually an adjustable pause in the filling of the spray agent tank.

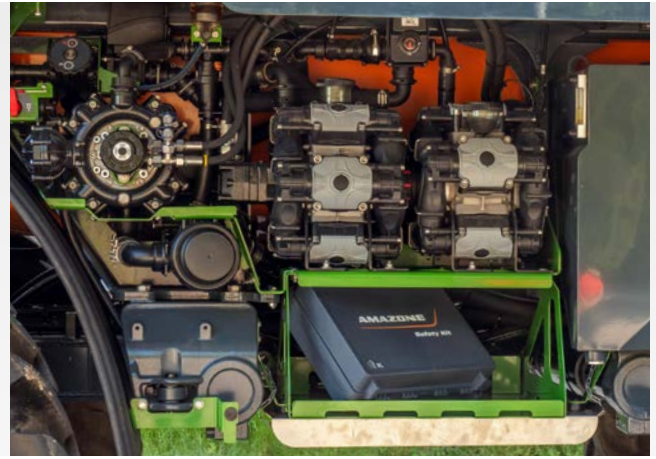

The fresh water pump (160 l/min) is located next to the two high-capacity piston diaphragm pumps

Fresh water pump

Comfort-Pack plus includes a fresh water pump with an output capacity of 160 l/min. This can be used to supply the induction bowl with fresh water from the fresh water tank during bowser filling.

The fresh water pump can be used to fill the fresh water tank and the spray agent tank in parallel via the suction port. The additional fresh water pump also enables faster cleaning of the Pantera.

Automatic and independent cleaning

The complete sprayer along with the induction bowl can be cleaned fully automatically. For this purpose, the Pantera with Comfort-Pack plus is equipped with the following cleaning programmes: intensive clean, quick clean and boom rinsing.

In addition, after every fill, the induction bowl rinses itself on its own.

The benefits:

- ✔ Simple operation: choose the function and the machine adjusts everything fully automatically
- ✔ Maximum comfort: automatic filling and automatic fill stop for both suction and bowser filling
- ✔ Maximum safety: fully automatic cleaning of the entire machine including the induction bowl
- ✔ Maximum capacity: automatic quick fill via the venturi when the chemical induction is completed
- ✔ Auto-dynamic agitation control

DirectInject direct feed system

Quick, flexible and needs-based metered addition of plant protection agents



Why use DirectInject?

The demands on farmers and technology are constantly increasing with regard to plant protection. Flexibility in the selection of plant protection agents in the field becomes an increasingly important point here. From a plant establishment perspective, the needs-based application of specific

products and active ingredients only in sections or on individual fields is a frequent response. There are also restrictions relating to protection-sensitive fields and bodies of water which farming must consider when selecting the appropriate plant protection agents.



Activation of DirectInject in the AmaTron 4 terminal



DirectInject tank with integrated sieve for easy and safe filling

System overview

DirectInject from AMAZONE is a system for the direct injection of plant protection agents. These can be injected or stopped during application as required. The special feature of DirectInject compared to conventional systems is the fast response time of the injection and its complete integration in the spray agent circuit and operation of the sprayer. DirectInject consists of an additional 50 l tank with its own metering system which is integrated between the cab and the main spray agent tank.

The advantages at a glance:

- ✔ Flexible, fast and needs-based use of plant protection agents
- ✔ Optimum crop canopy
- ✔ Environmentally-friendly
- ✔ Saving on:
 - Working time and labour costs
 - Machine costs
 - Plant protection agents

Application in the field

If the driver of the Pantera notices, for instance, a prevalence of unwanted weeds which need to be controlled in a specific part-area, they can activate the DirectInject metering system from the cab at the touch of a button. The supplementary product from the DirectInject tank is then added to the spray agent from the spray agent tank in the mixing chamber. The optimised reaction time compared to conventional systems is achieved by a twin-line system. Pre-mixed spray agent from the spray agent tank and the plant protection agent from the DirectInject tank are held in a second spray line in the boom. When the direct feed system is activated, the mixture is supplied to the nozzle bodies via several injection points on the boom and applied. This guarantees minimal reaction times. In this regard, the valve for the spray agent from the spray agent tank and the valve for the second spray line with the pre-mixed DirectInject agent are switched alternately, meaning that spray agent is only taken from one line at any time.

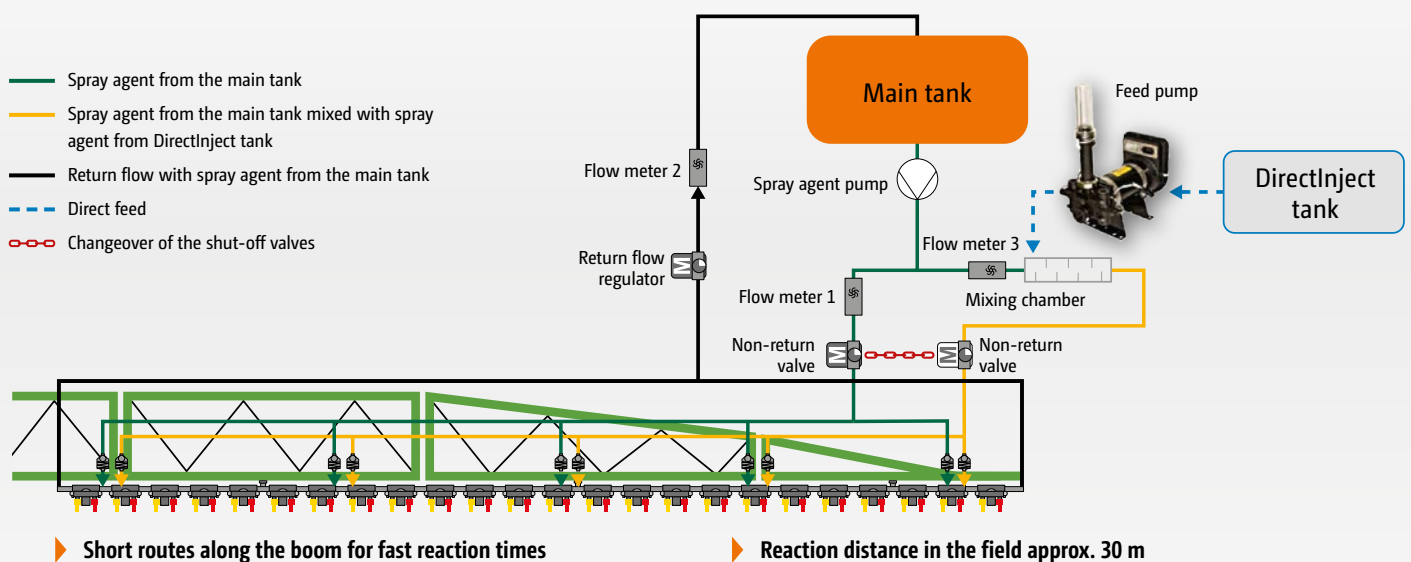

Operating options at a glance

| | | Comfort-Pack | Comfort-Pack plus |
|--------------------------|---|--------------|-------------------|
| Operation: suction side | Electrically actuated via TwinTerminal 3.0 | | - |
| | Electrically actuated via pressure-sensitive TwinTerminal 7.0 | - | |
| Operation: pressure side | 7-way pressure tap | | - |
| | Electrically actuated via pressure-sensitive TwinTerminal 7.0 | - | |
| Bowser fill | - fresh water tank with Geka coupling | | |
| | - with non-return valve | | |
| | - free-flow return (from above into the tank with lid opened) | | |
| | - automatic fill stop for the spray agent tank and the fresh water tank | | |
| Functions Suction valve | Drawing in via the suction port | | |
| | - automatic fill stop for suction port | | |
| | Drawing in via spray agent tank / fresh water tank | | |
| | Dry coupling connection port | | |
| Functions Pressure valve | Filling the spray agent tank & drawing out of the induction bowl via the venturi | | |
| | Liquid at the induction bowl (rinse ring, high-pressure nozzle, jet nozzle, hand lance) | | |
| | Forced emptying | | |
| | Internal cleaning | | |
| | External cleaning with fresh water | | |
| | Spraying | | |
| | Filling of fresh water tank | | |
| | - with automatic fill stop | - | |
| Additional functions | Automatic cleaning of the induction bowl | - | |
| | 2 individually programmable fill profiles | - | |
| | Adjustable filling and foam damping function | - | |
| | Electric emptying of spray lines and filters | - | |
| | Capacity increase for canister cleaning | | |
| | Fresh water pump with continuous internal cleaning | - | |
| Agitation | Fill level dependent agitator output | | |
| Cleaning | Remote cleaning control from the in-cab terminal | | |
| Other systems | HighFlow+ | | |
| | DirectInject | - | |

■ = included

■ = optional

- = not possible

Comfort-Pack

Comfort-Pack plus

The induction bowl

Perfect operator comfort via the simple and centralised controls



High performance and efficient

The induction bowl is located directly in front of the control panel and holds 60 l. The conical form of the bowl, with central outlet and an enormous suction rate of more

- ✔ The control tap feature means that fresh water is always available at the induction bowl during both suction and bowser filling.

than 200 l/min, ensures fast and trouble-free filling and complete emptying.

Advantages of the induction bowl:

- ✔ Draw out rate of up to 200 l/min – for fast and trouble-free filling and complete emptying
- ✔ Infinitely variable mixing nozzle – prevents any clogging of powdery and granular spray agents
- ✔ Infinitely variable high-capacity rinse ring
- ✔ In conjunction with Comfort-Pack plus, the induction bowl can be permanently supplied with high water pressure via the fresh water pump during bowser filling.
- ✔ Dust- and leak-proof induction bowl lid as a practical storage option with integrated drain-off device
- ✔ Canister rinse nozzle with practical pressure plate for cleaning the measuring jug and chemical canisters
- ✔ Small contact area on the canister rinse nozzle where the nozzle can be activated for cleaning the canister neck



The lid is provided with holders for measuring jugs or spray agent canisters, in order to allow them to drain after rinsing.



The closed induction bowl can be flushed for self-cleaning.

Boom in aircraft wing design

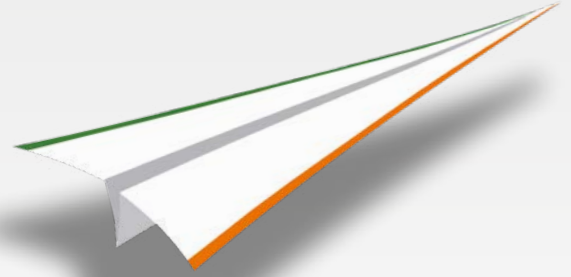

Large height adjustment range from 0.35 m to 2.65 m via the sprung parallelogram (on Pantera 4504 with 380/90 R50 tyre sizes)

Super-light yet super-stable

Thanks to the special profile design, AMAZONE booms are at the same time superbly light and superbly strong. Boom widths from 21 to 48 m allow optimum adaptation of the sprayer to the structure of the farm. The exceptional high quality ensures a long operational life even over very high acreages.

Compact transport dimensions with transport widths from 2.55 m contribute to safe road transport.



- ✔ The hydraulic fittings made from stainless steel ensure a long service life and a high resale value.

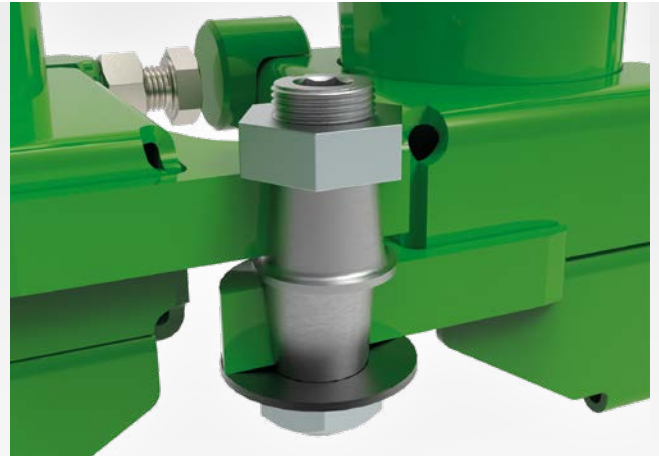

- ✔ A pivot joint that lasts!
The boom pivots self-adjust against any play on the conical hinge pins, thereby ensuring an optimised boom function for the end user, even after many years.

Maintenance-free and with a long service life

The decades of experience in boom design pays off: the conical hinge pin is the intelligent centre of a well thought-out boom philosophy! The boom pivots self-adjust against any play on the conical hinge pins, thereby ensuring an optimised boom function for the end user, even after many years.

The standard use of stainless steel, the use of automotive-industry standard, cathodic dip painting process and the targeted use of plastics and aluminium are the perfect guarantee of a long service life.

High-quality, multi-layer paint

A high-quality multi-layer paint finish guarantees top quality that lasts

- 1) Sheet steel
- 2) Zinc phosphate (galvanising layer)
- 3) CDP priming
- 4) Top coat

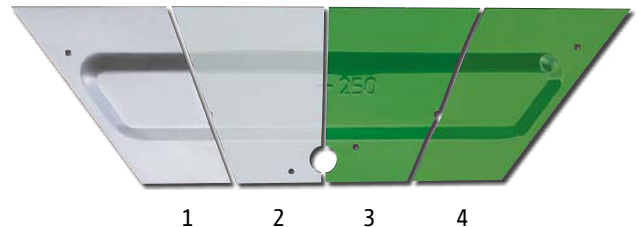

- ✔ Everything is shipshape: the boom is located safely without movement in its transport position. The parallelogram suspension dampens shock loads in the field as well as in the transport position. This is pure comfort and, above all, ensures the long service life of the boom.

- ✔ Compact transport dimensions:
 - 2.55 m wide
 - 3.90 m high

Super-L2 boom

Super-light, super-stable and super-compact for widths up to 36 m



Super-L2 boom suspension

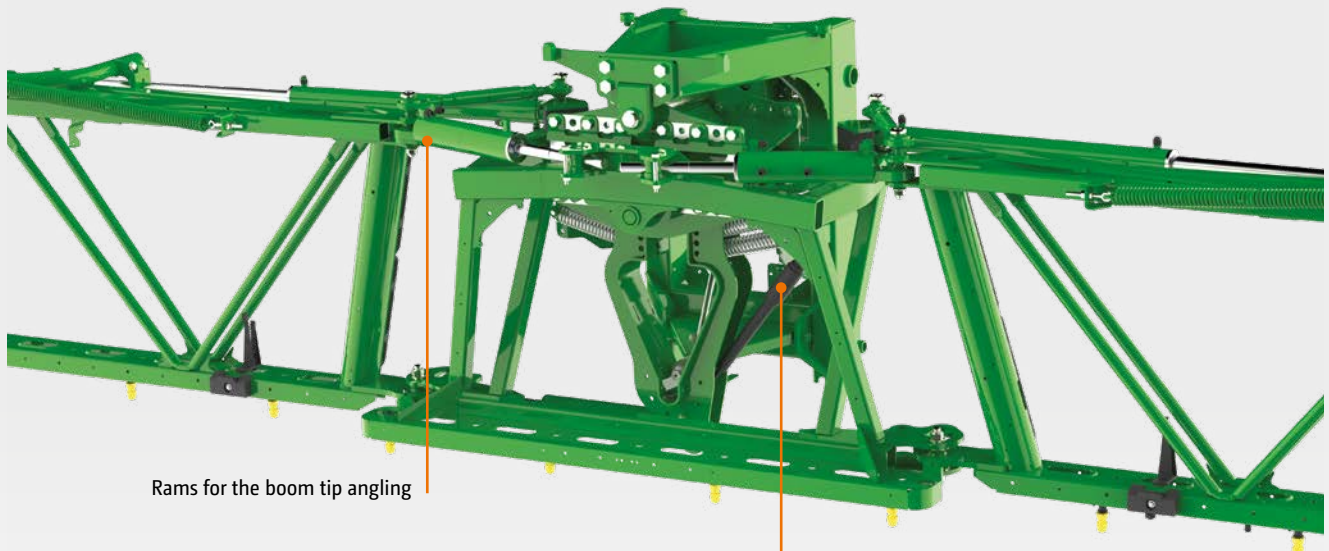

Rams for the boom tip angling

Spring damping system for reducing the vertical swing movement



Super-L2 boom with a width of 36 m, folds down to 30 m, 24 m and 12 m

Super-L2 boom in boom widths from 21 to 36 metres

Superbly narrow transport width of just 2.40 m on all three-fold Super-L2 booms in boom widths of 21, 24, 27 and 28 m. Amazing transport width of only 2.60 m on all four-fold Super-L2 booms in boom widths of 27, 28, 30, 32, 33 and 36 m.



Wide boom profiles with multiple folds provide maximum rigidity yet with a very low weight.

Potential folding widths of the Super-L2 boom

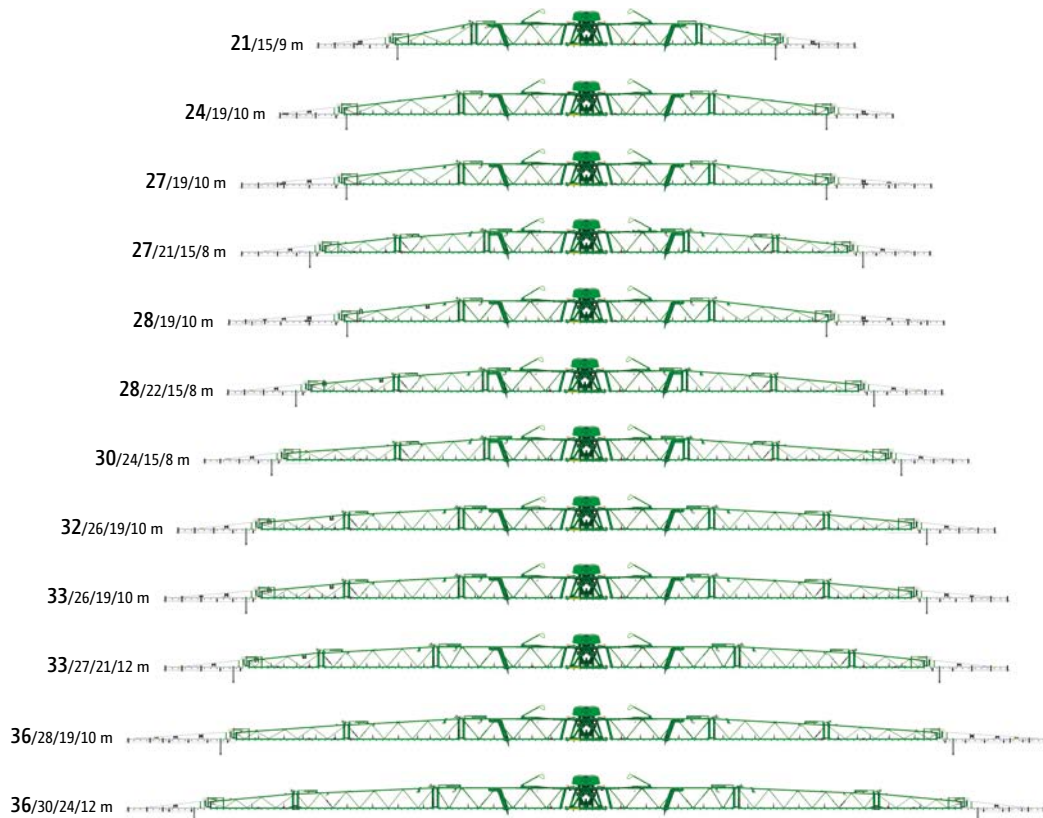

Super-L3 boom

Super-light, super-stable and super-compact for widths up to 48 m



Super-L3 boom suspension from a width of 39 m

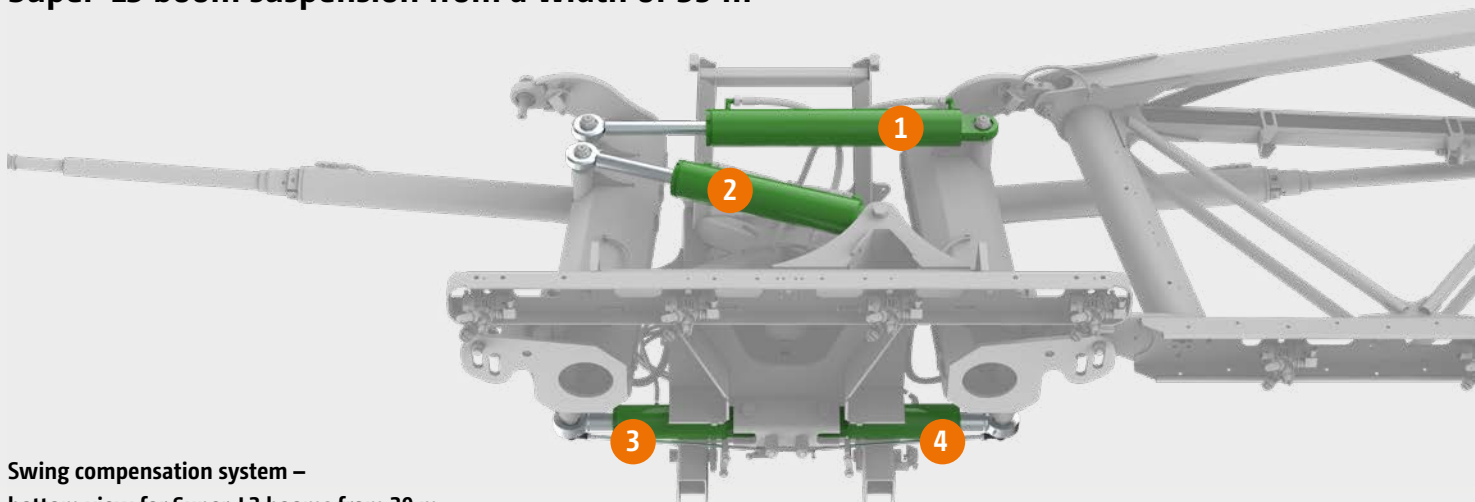

Swing compensation system – bottom view for Super-L3 booms from 39 m

- ① Positive angling cylinder: Positive and negative angling of the right-hand boom section
- ② Tilt cylinder: tilt adjustment of the entire boom in conjunction with the positive angling cylinder (1) Positive and negative angling of the left-hand boom section
- ③ SwingStop plus cylinder, left: active swing compensation of the left-hand boom section
- ④ SwingStop plus cylinder, right: active swing compensation of the right-hand boom section



Super-L3 boom with a width of 36 m, folds down to 24 m and 12 m

Super-L3 boom in widths from 30 to 48 metres

The special AMAZONE profile design of the boom provides maximum stability with a low weight. The inner boom sections of the Super-L3 boom are made of steel. The outer boom sections are manufactured from aluminium to keep the total weight down to a minimum. The advantage of the light-weight outer boom sections is that only a little amount of extra weight has to be guided smoothly over the crop on the outside. Smooth boom guidance at the boom ends is extremely important, especially in the case of these larger working widths. The profiles of the penultimate boom section of the 48 m wide Super-L3 boom are made of carbon fibre for maximum rigidity with a low weight.



The hydraulically pressurised break back system on the boom end (which works just like the saloon door principle) can cope with obstacles from the back, front or from the top and ensures a reliable return to the working position and a long service life.

Always the best level of equipment

Super-L3 booms from a width of 39 m are equipped as standard with ContourControl active boom guidance, SwingStop plus boom tip swing compensation and AmaSwitch or AmaSelect individual nozzle control with DUS pro in each case.

The over-engineered boom sections, with hydraulically pressurised break back joints in the boom ends, ensure an absolutely smooth boom ride under any conditions. If any vibrations caused by cornering or acceleration occur in spite of the massive design, they are directly reduced by SwingStop plus.

Potential folding widths of the Super-L3 boom

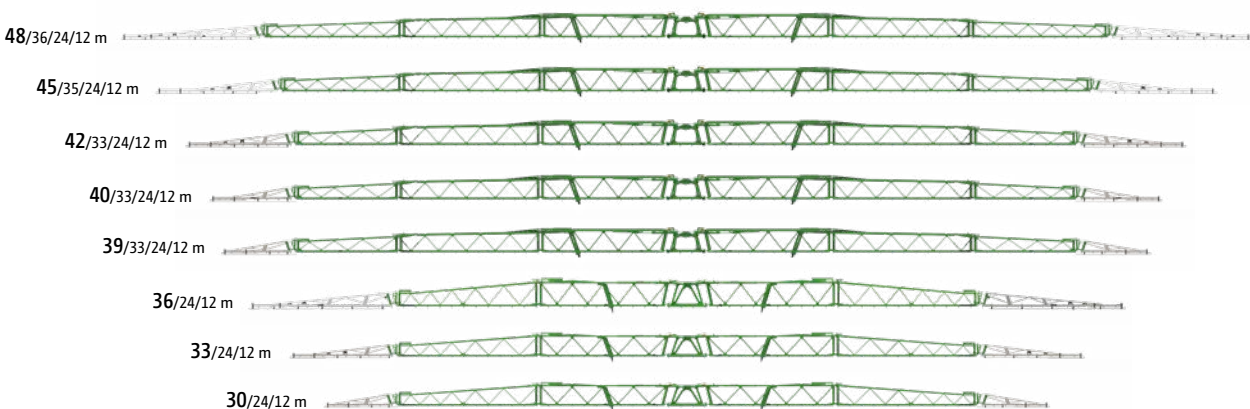

Flex-fold

The outstanding made easy



✔ The Pantera 4504 with Flex-fold 2 and ContourControl enables optimum boom guidance with positive and negative angling of the boom, suitable even in the most challenging of terrain conditions

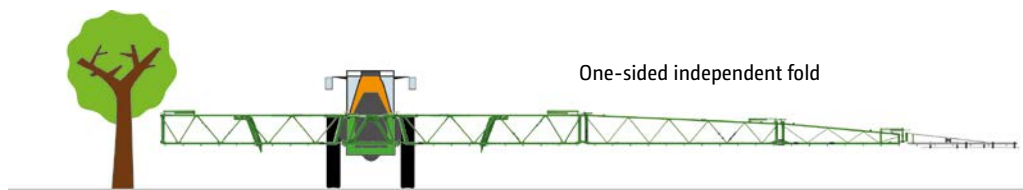

One-sided independent fold (via Flex-fold 1)



Positive angling (via Flex-fold 2)

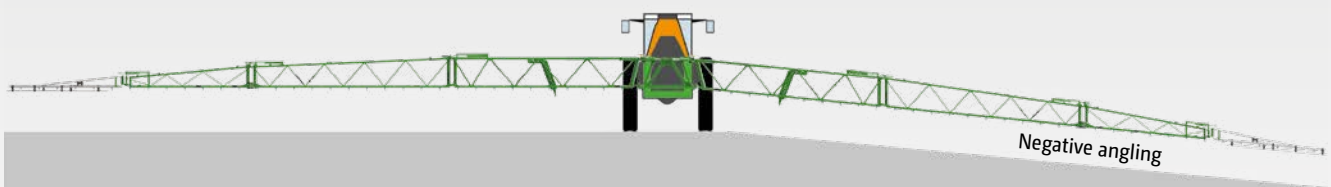

Negative angling (via Flex-fold 2 in combination with ContourControl)

Flexible, fast and accurate

Reduction, angling, one-sided independent fold

Flex-fold for Super-L2 and Super-L3 booms

AMAZONE offers two electro-hydraulically actuated boom fold options, Flex-fold 1 and Flex-fold 2. Each boom folding joint is equipped with an electro-hydraulic valve block that is directly controlled by the machine software. This enables faster folding. As soon as the first boom section is folded in or out by approximately 70%, the next section automatically starts to fold in or out.

Individual user profiles for reduced working widths

Via the user profiles in the machine software, individual profiles that recognise a reduced working width can be stored. If e.g. it is intended to fold out a 36/30/24 m boom to just 30 m, this can be carried out quickly and simply via a profile change. After folding out, the active working width is automatically detected and the outer nozzles are deactivated via the AmaSwitch or AmaSelect individual nozzle control. The reduced working width is automatically stored for Section Control.

Flex-fold 1

In addition to the benefits already outlined, Flex-fold 1 provides the following extra functions:

- ✔ Height adjustment
- ✔ Folding in and out
- ✔ One-sided independent fold at reduced speeds (max. 6 km/h)
- ✔ Boom width reduction
- ✔ Tilt adjustment

Flex-fold 2

In addition to the advantages mentioned previously, Flex-fold 2 offers the following functions:

- ✔ One-sided/simultaneous positive boom angling
- ✔ One-sided/simultaneous negative boom angling (in combination with ContourControl)

- ❗ "To speed up the folding procedure, AMAZONE has replaced the simple sequence control by a sensor controlled process. With this we clocked a quick 19 seconds for folding out and 27 seconds for folding in – great!"

("profi" – Test report Amazone UX 5201 Super - 10/2017)

Boom guidance

With maximum comfort and even more precision



✔ Automatic boom pre-lowering in GPS-Switch

The GPS-Switch function in the operator terminal can be used to start lowering the boom before it reaches the untreated area. This means that the boom is already at the correct working height when the nozzles come on.

Requirements for this function are just a field boundary saved within the GPS-Switch in the AMAZONE ISOBUS terminal.

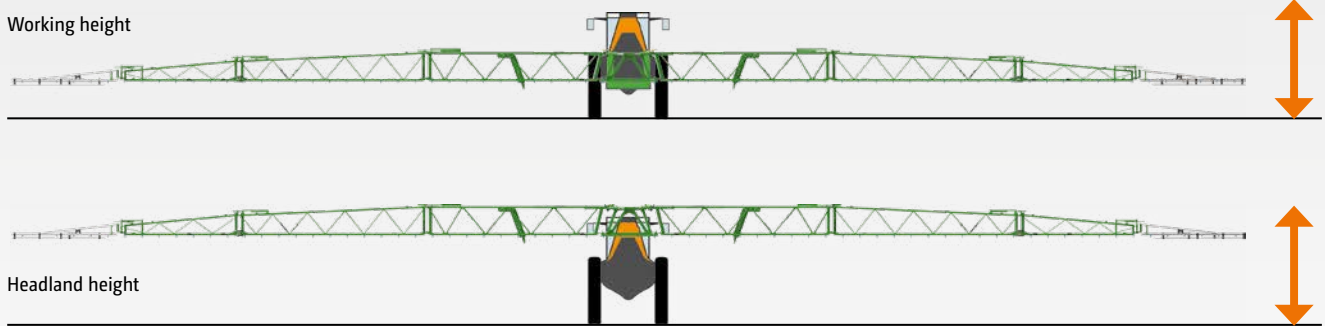

AutoLift – the comfortable automatic headland system

AutoLift automatic boom lift (standard equipment) lifts the boom to a pre-selected height every time the machine is switched off.

It lowers back down again to the target height when the sprayer sections are switched on. This reduces the risk of damage to the boom while turning on the headland.

DistanceControl or ContourControl? Decide for yourself!

The DistanceControl and ContourControl automatic boom guidance systems offered by AMAZONE provide a suitable solution for every demand. The fully automated DistanceControl boom guidance leaves the control of your sprayer boom in the hands of the machine.

The innovative ContourControl boom control is AMAZONE’s high-end solution, ideal for customers with difficult terrain conditions. ContourControl provides maximum precision, even at high forward speeds.

DistanceControl with 2 sensors or DistanceControl plus with 4 sensors

As an option on the Super-L boom, AMAZONE offers the DistanceControl fully automated boom guidance system with 2 sensors or DistanceControl plus with 4 sensors for the Pantera self-propelled sprayer. DistanceControl with 4 sensors is recommended if the crop height varies greatly or there are areas with partially lodged corn. The sensors are electrically connected in parallel and so it is always the sensor that is closest to the target surface that is sensing.

Benefits of the DistanceControl boom guidance

- ✔ Fully automatic boom guidance including boom height, tilt adjustment and boom lifting on the headland
- ✔ Automated simultaneous boom angling, in combination with Flex-fold 2

✔ DistanceControl plus

The driver is able to concentrate on correctly applying the plant protection agent, while the technology looks after the optimal boom guidance!

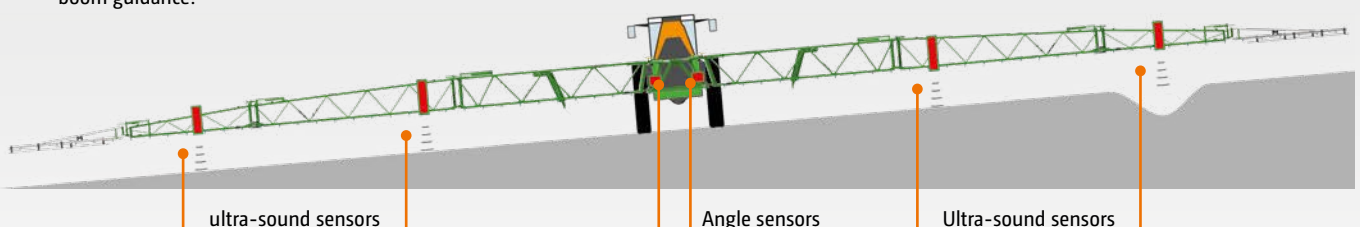

ContourControl and SwingStop

Active boom guidance and boom tip swing compensation under difficult conditions

ContourControl – Reduces those vertical boom movements

With the active boom guidance system, ContourControl, AMAZONE offers a fully automatic boom guidance system for booms from 21 m working width. This meets the increasing demand for higher precision during application owing to the minimal deviations in the distance from the target surface, even at high forward speeds and large working widths. ContourControl can be used with Super-L booms in conjunction with either Flex-fold 1 or Flex-fold 2.

The basis of the new boom guidance system is a highly responsive electro-hydraulic system and 4 sensors, or as many as 6 sensors in combination with Flex-fold 2, which enable both automatic positive and negative angling.



Super-L2 boom suspension

The benefits of ContourControl:

- ✔ Optimum lateral distribution
- ✔ Precise, super-fast automatic height guidance
- ✔ Target surface distance below 50 cm – less drift
- ✔ Very quick folding processes
- ✔ Higher accuracy at faster working speeds
- ✔ Elegant boom control for those wider working widths

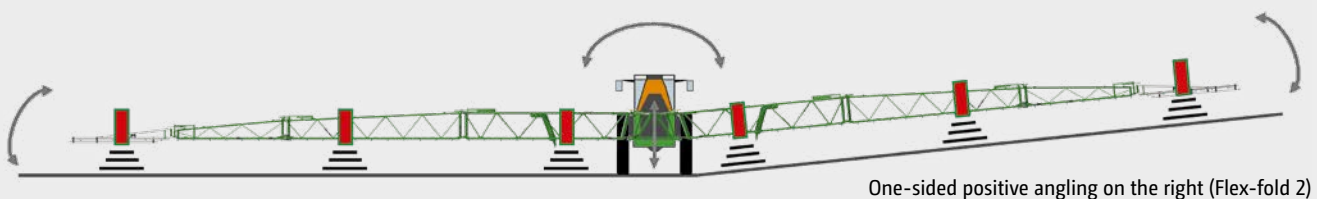

One-sided positive angling on the right (Flex-fold 2)

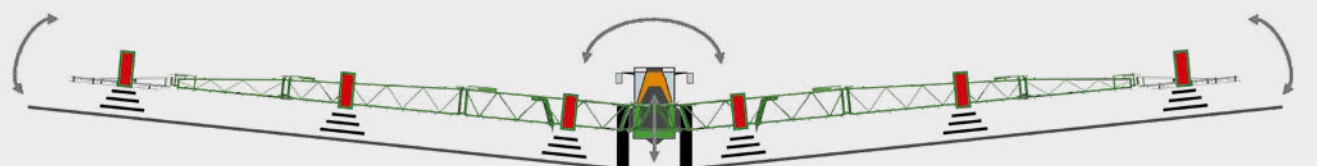

Simultaneous positive angling (Flex-fold 2)

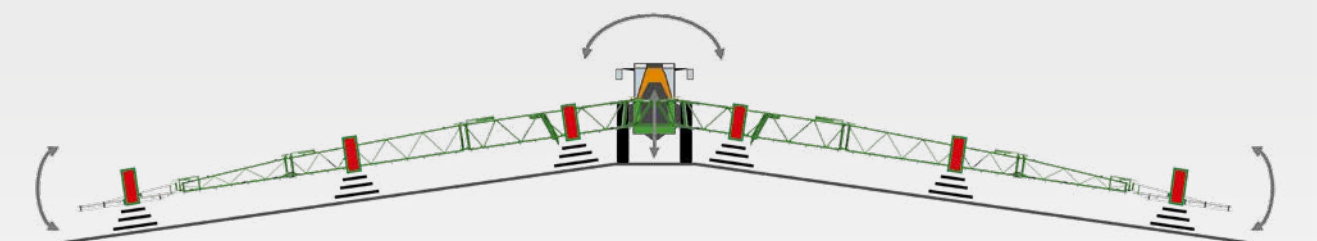

Simultaneous negative angling (Flex-fold 2)

Fast and precise – at the same time

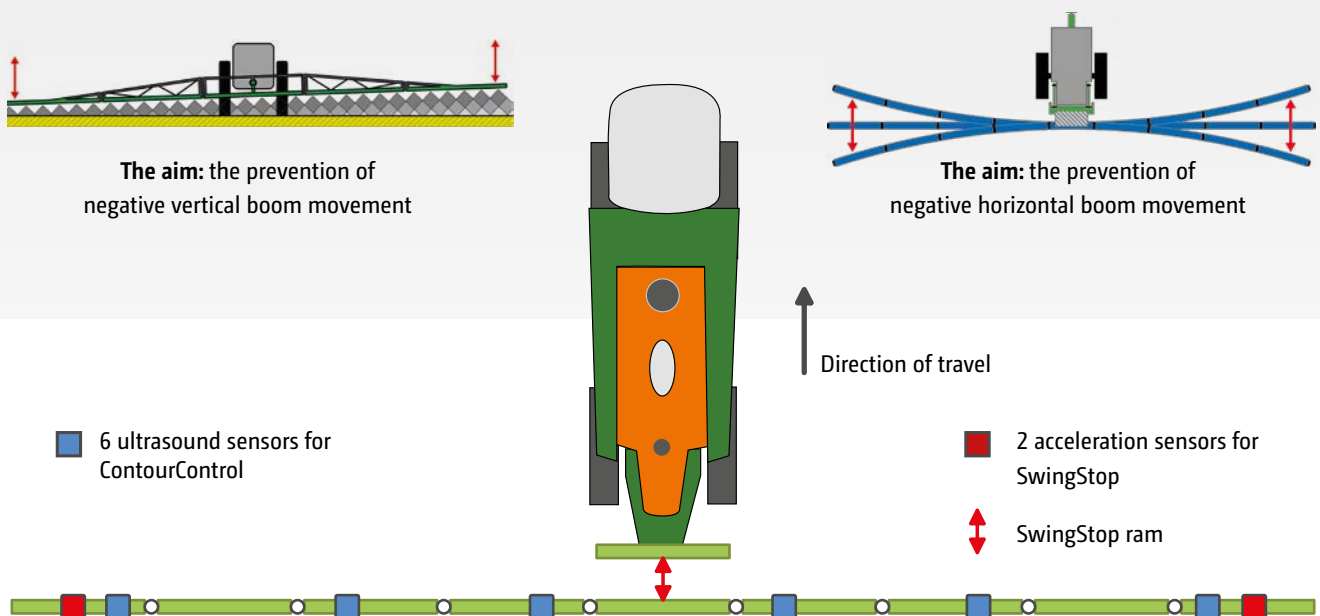

SwingStop – For reducing the horizontal boom movement

In order to tailor the horizontal boom ride to the growing demands, e.g. wider working widths and higher forward speeds, AMAZONE offers SwingStop active boom tip movement prevention as an option for the ContourControl boom guidance system. By external influences, such as ground undulations, driving round bends, acceleration and deceleration and increasing operating speeds, the boom is under extraordinary strain in the horizontal plane. This may result in the boom ends swinging back and forth and thus negatively affecting the lateral distribution at the outer ends of the booms.

Since horizontal movement occurs more at the boom ends, this effect is amplified by large boom widths. To reduce this horizontal tip swing effect, SwingStop measures, via acceleration sensors, the resulting acceleration at the boom ends. The two actively operating hydraulic rams in the boom suspension compensate live for these swing movements and in this way provide a very smooth horizontal boom ride.

The benefits of SwingStop:

- ✔ Optimum longitudinal distribution
- ✔ Reduction of the horizontal boom movement for a very smooth boom ride
- ✔ A system which operates very quickly and precisely, even at high working speeds
- ✔ Highest performance and outstanding precision

❗ "A total of six ultrasound sensors take care of the height guidance of the parallelogram frame, the adjustment of the slope compensation and the control of the boom angling (positive and negative). It is fantastic in hilly terrain, particularly when it comes to being able to spray more quickly and with a shorter distance above the target surface."

("profi" - "Practice test Amazone UX 4201 Super" 02/2020)

❗ "And now when it comes to the keyword "fast", then "SwingStop" also comes into play: This is an active, hydraulic control system with acceleration sensors in the ends of the boom which counteracts horizontal swinging - and does so before any movement visible to the eye occurs."

("profi" - "Practice test Amazone UX 4201 Super" 02/2020)

SwingStop plus

The right solution for every requirement



Swing compensation system for Super-L3 booms from 39 metres

SwingStop plus – independent boom tip swing compensation for both halves of the boom

A new swing compensation system is installed on Super-L3 booms in widths from 39 m which includes the new SwingStop plus boom tip swing compensation. This offers the well-known advantages of SwingStop but differs in that the movements of the two halves of the boom are hydraulically damped independently of each other in the direction of travel. This provides an even better basis for optimum longitudinal distribution of the application.

Reducing symmetrical and asymmetrical vibrations

SwingStop plus can compensate for symmetrical oscillations which occur through acceleration and braking extremely effectively. The new design of the swing compensation system now permits the individual control of either boom half. In SwingStop plus, each boom section is equipped with a hydraulic cylinder which actively counteracts any oscillations which occur in that boom half. This means that even asymmetrical boom oscillations which occur after negotiating bends are effectively reduced.

Symmetrical oscillation
mainly during field work

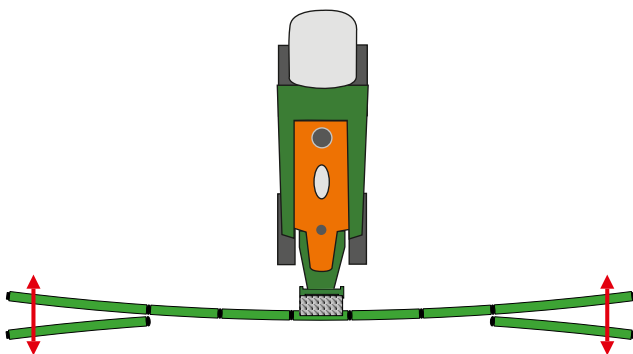

Asymmetrical oscillation
mainly during and after bends

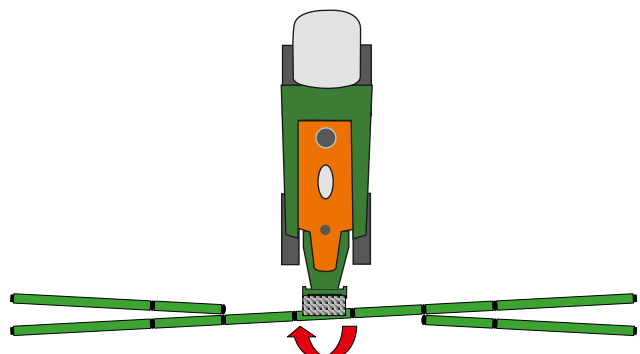

Overview: boom guidance

The right solution for every requirement

| Boom functions | Pantera 4504 / 7004 | | | |
|--|---|-------------|----------------|---------------------------------|
| Folding | Flex-fold 1 | Flex-fold 2 | Flex-fold 1 | Flex-fold 2 |
| Automatic boom guidance (option) | DistanceControl (plus) | | ContourControl | |
| Number of relevant sensors | 2 (4) | | 4 | 6 |
| Sprayer boom folding in and out | remotely controlled (ISOBUS terminal) | | | |
| One-sided, independent boom fold | remotely controlled (ISOBUS terminal) | | | |
| Folding in to a reduced working width | automatic | | | |
| Break back protection at reduced working width | Standard | | | |
| Folding time | quick | | very quick | |
| Height adjustment | remotely controlled (ISOBUS terminal) / automatic with DistanceControl or ContourControl | | | |
| Boom lift on the headland | remotely controlled (ISOBUS terminal) / automatic with DistanceControl or ContourControl | | | |
| Adjustment of tilt | remotely controlled (ISOBUS terminal) / automatic with DistanceControl or ContourControl | | | |
| One-sided/simultaneous positive boom angling | — | automatic | — | automatic |
| One-sided/simultaneous negative boom angling | — | | — | automatic |
| Active horizontal boom tip swing compensation (option) | — | | SwingStop | SwingStop / SwingStop plus * |
| Boom guidance (overall view) | good | | excellent | |
| Recommendation for working widths | — | | > 30 m | |
| Recommendation for operating speeds | medium | | extremely high | |
| Recommendation for ground conditions | level | hilly | level | hilly |

* from boom widths of 39 m

TG part-width section valves



Electrically controlled TG valve chest

The TG part-width valve chest with up to 13 part-width sections is available with ISOBUS control. The part-width sections are switched quickly and without drips via electric motor valves with pressure relief. The spray rate is precisely and quickly controlled directly by the machine's job computer in all situations.



Single and multi-nozzle bodies

The nozzle bodies with integrated diaphragm non-return anti-drip valves fit up into the boom profiles reliably preventing any dripping at the nozzle. Self-adjusting bayonet fixings ensure a tool-less quick nozzle change. The triple or quad nozzle bodies are suited to frequent nozzle changes due to different applications and crops.

AMAZONE offers a wide range of nozzles from agrotop, Lechler and TeeJet.

DUS pressure recirculation system

High output and reliable



DUS pressure recirculation system

The DUS pressure recirculation system – proven more than 10,000 times

The AMAZONE DUS pressure recirculation system ensures a reliable circulation throughout the entire system. When starting the spraying operation, all the hoses including the spray lines are filled under pressure in the reverse direction with the pre-mixed spray agent. This means the spray lines are always full and immediately ready to use over the entire working width. There is no waiting on the headland.

Every time individual part-width sections are shut off, during the turning operation and during transport, the spray liquid circulates continually thanks to the pressure recirculation system. This reliably prevents deposits, blockages or segregation in the spray lines.

During the cleaning operation, fresh water flushes the spray lines out right up to the nozzles without any spraying being necessary. During this cleaning procedure, the concentrated spray liquid is returned back to tank via the pressure recirculation system leaving the spray lines clean.

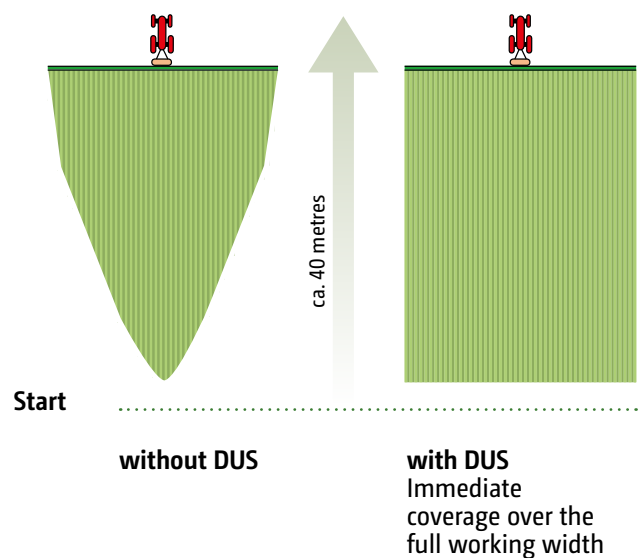

DUS pressure recirculation system with part-width section switched off

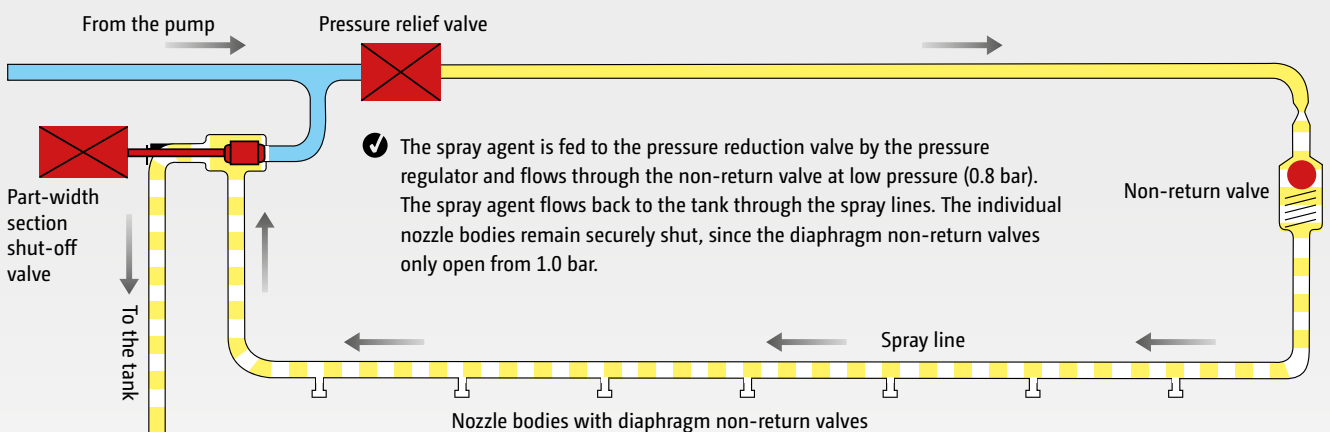

AmaSwitch

Electric individual nozzle switching with 50 cm part-width sections

The simple solution for automatic 50 cm part-width section control

With AmaSwitch, AMAZONE offers the precise solution for automatic part-width section control on 50 cm sections. AmaSwitch is the ideal alternative for users who want to maximise the benefits of very precise switching in wedge shaped fields and areas of overlap, thanks to the 50 cm part-width section control.

AmaSwitch includes the DUS pro high-pressure recirculation system as standard and can also be equipped with LED individual nozzle lighting.

Equipped with the DUS pro pressure recirculation system as standard

As in the case of DUS, the spray pressure in DUS pro is constant up to the individual nozzle and remains at the pre-set spray pressure. In addition, minimal residual spray volumes are achieved thanks to the conical spray lines.



AmaSwitch 3-fold nozzle body

DUS pro – constant spray pressure with minimal residual volumes

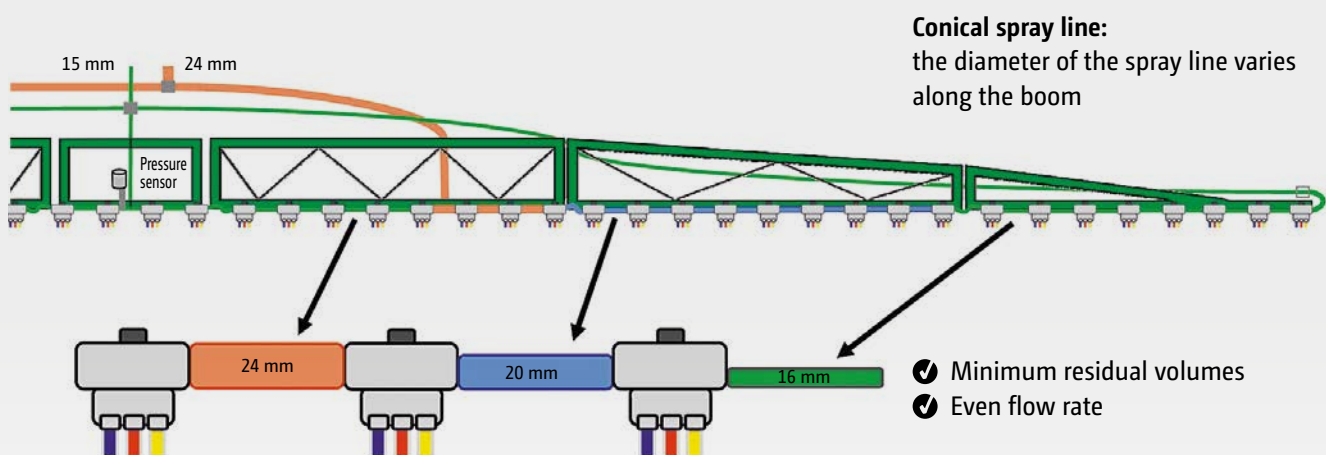

DUS pro high-pressure circulation system with conical spray line, such as with AmaSwitch, as an example



AmaSwitch triple nozzle body with LED individual nozzle lighting

Triple nozzle body with electric on/off switching

The technology behind AmaSwitch is based on a conventional, manually rotated, triple nozzle body with electric individual on/off. The opening and closing is achieved via an electric valve which is fixed directly onto the nozzle body. In conjunction with GPS-Switch, it is thus possible to very precisely control 50 cm part-width sections in short work and on the headland. In addition to the automatic switching using 50 cm part-width sections, it is also possible to configure the amount of part-width sections from choice.

Quad nozzle body with electric on/off switching

In addition to the triple nozzle body, AmaSwitch electric individual nozzle control can also be equipped with a quad nozzle body.

With true 25 cm nozzle spacing

The quad nozzle body enables a perfect 25 cm nozzle spacing to be achieved with the aid of the optional off-set kit. In conjunction with special 80° nozzles, this offers the benefit of reducing the boom to target surface distance down to less than 50 cm.



AmaSwitch quad nozzle body

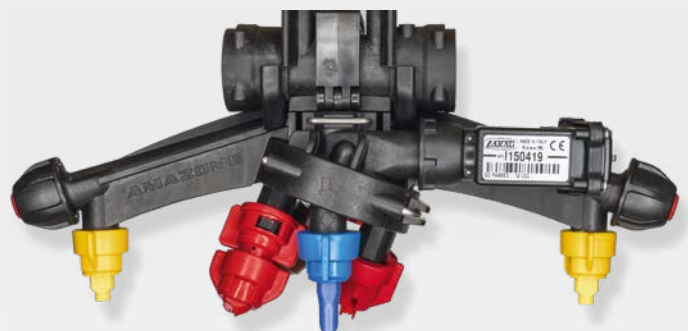

AmaSwitch with quad nozzle body and off-set kit for a perfect 25 cm nozzle spacing

AmaSelect

Electric individual nozzle control with 50 cm part-width section and nozzle switching

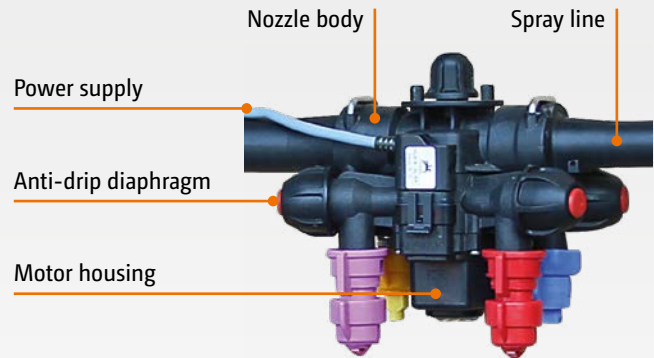

AmaSelect – components of the system

Quad nozzle body with automatic electric nozzle switching

The electric AmaSelect individual nozzle control consists of a quad nozzle body with electric on/off control plus the additional switching over of either a nozzle or a combination of nozzles. In addition to the 50 cm part-width sections, which can be switched automatically via GPS-Switch, the system offers electrical switching between the four mounted nozzles via the operator terminal or even completely automatically if the forward speed or application rate is changed. This offers the possibility, for instance when leaving the optimum pressure range of a nozzle, to switch on a second nozzle or to changeover to a larger nozzle.

Flexible configuration of working widths and part-width sections

AmaSelect enables any number of part-width sections with any number of nozzles to be freely configured. So for farmers or agricultural contractors with different tramline systems, a simple matching of the nozzle switching with the relevant working width is possible.

Automatic 50 cm part-width section control via GPS-Switch with Section Control

The automatic control of individual nozzles in 50 cm part-width sections is made possible by combining the AmaSelect individual nozzle control with GPS-Switch (with Section Control). This enables the amount of overlap to be considerably reduced, meaning that there is a significant saving in spray agent.

With true 25 cm nozzle spacing

As an option, the AmaSelect nozzle body can also be equipped with an off-set kit giving 25 cm nozzle spacing. In conjunction with special 80° or 90° nozzles, this offers the benefit of reducing the boom to target surface distance to less than 50 cm.

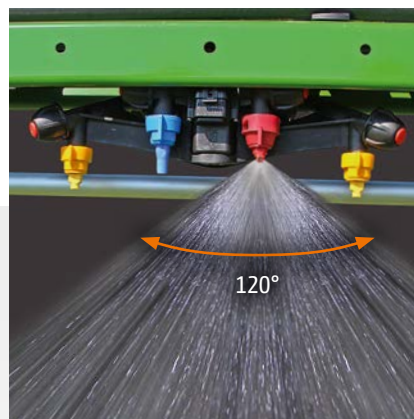
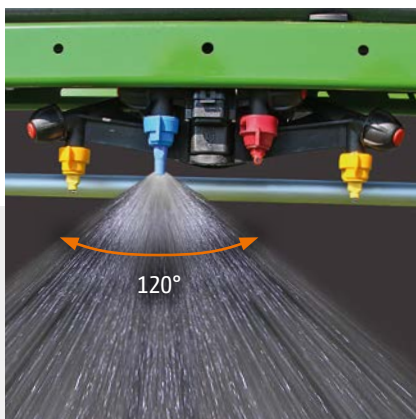

AmaSelect electric individual nozzle control with quad nozzle body and 50 cm and 25 cm nozzle spacing



HeightSelect – always the optimum target surface distance

With the aid of HeightSelect (only in conjunction with AmaSelect), the distance between the boom and the target crop is now also continuously adjusted automatically depending on the nozzle spacing and nozzle type. When the nozzle has been switched on, the automatic boom guidance system controls the appropriate target distance. This automisation improves the efficiency of the crop protection agent used as well as decisively relieving the stress on the driver.

High-End as standard – LED individual nozzle lighting and DUS pro

AmaSelect is equipped with the DUS pro high-pressure recirculation system and LED individual nozzle lighting as standard.

The crop protection technology of the future is already here

AmaSelect individual nozzle control offers the potential for absolute precision with the additional optional functions AmaSelect Curve-Control, AmaSelect Row and AmaSelect Spot.

Principle of function of HeightSelect

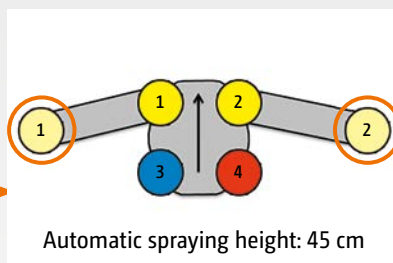
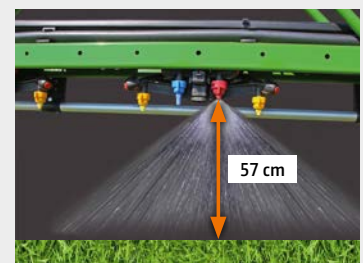
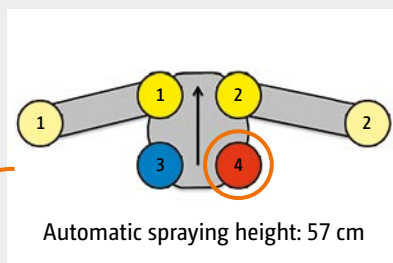

Electric individual nozzle control AmaSwitch and AmaSelect

Example: 24 m working width

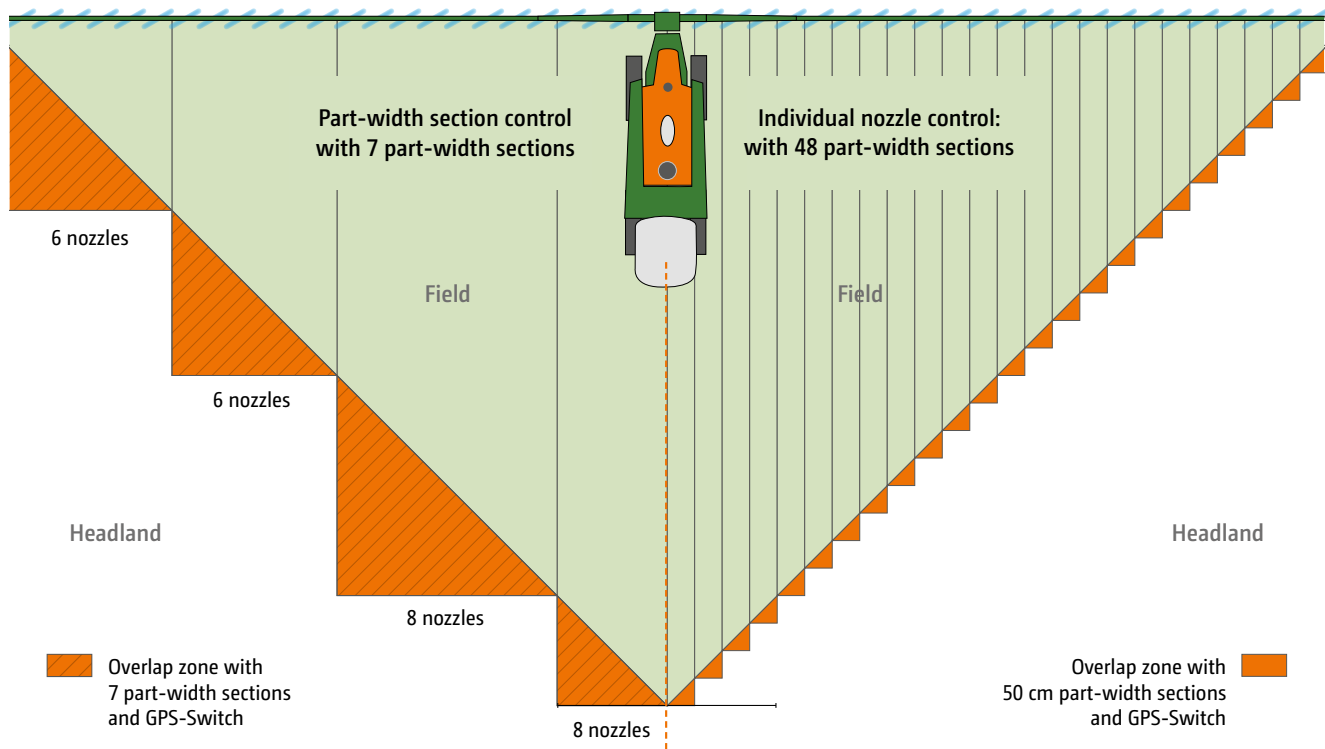

Automatic part-width shut-off on the headland and in wedge-shaped fields **GPS-Switch**

5%*

Saving on crop protection agent usage



Electric individual nozzle control **AmaSwitch or AmaSelect**

5%*

Additional saving in crop protection agent usage

* Savings are dependent on field shape, boom width and the number of part-width sections



✔ AmaSwitch electric individual nozzle control



✔ AmaSelect electric individual nozzle control

Calculated example:

Annual average overlap of **conventional part-width sections vs 50 cm part-width sections in combination with Section Control**

Important knowledge for field analysis

- ✔ Average overlap with 50 cm part-width sections only 1.92%
- ✔ Average overlap with 9 part-width sections 7%
- ✔ Short payback period for larger farms due to the annual potential savings
- ✔ Due to smaller field sizes, smaller farms save proportionally more
- ✔ When growing crops with a high crop protection demand (e.g. potatoes, sugar beet), 50 cm part-width sections are particularly cost-effective

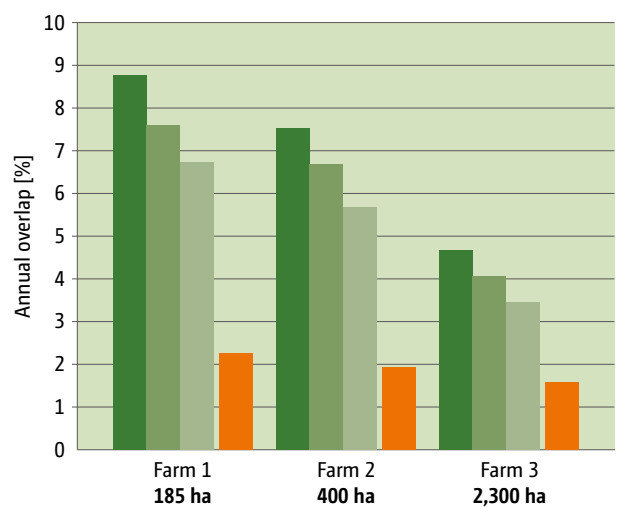

Level of equipment on crop protection sprayers:

- 9 part-width sections
- 11 part-width sections
- 13 part-width sections
- 50 cm part-width section individual nozzle control

Comparison of systems:

| The benefits | Standard valve chest | AmaSwitch Triple | AmaSwitch Quad | AmaSelect |
|---|----------------------|------------------|----------------|-----------|
| Multiple boom sections | up to 13 | up to 96 | up to 96 | up to 96 |
| 50 cm part-width sections | – | ■ | ■ | ■ |
| Number of nozzles per nozzle body | 1, 3, 4 | 3 | 4 | 4 |
| Manual nozzle switching | ■ | ■ | ■ | – |
| Automatic nozzle changeover and switching | – | – | – | ■ |
| Nozzle selection from the cab | – | – | – | ■ |
| Nozzles used in combination | – | – | – | ■ |
| High-pressure circulation system (DUS pro) | – | ■ | ■ | ■ |
| 25 cm nozzle spacing (off-set kit) | – | – | ■ | ■ |
| Individual programming of the part-width sections (TB) | – | ■ | ■ | ■ |
| LED individual nozzle lighting | ■ | ■ | ■ | ■ |
| Switching to band application from the cab (AmaSelect Row) | – | – | – | ■ |
| Optimised application rate during cornering (AmaSelect CurveControl) | – | – | – | ■ |
| Part-area, site-specific application on the basis of spot application maps (AmaSelect Spot) | – | – | – | ■ |

Nozzle switching –system overview

■ = included

■ = optional

– = not possible

AmaSelect CurveControl

Optimised application when driving round bends



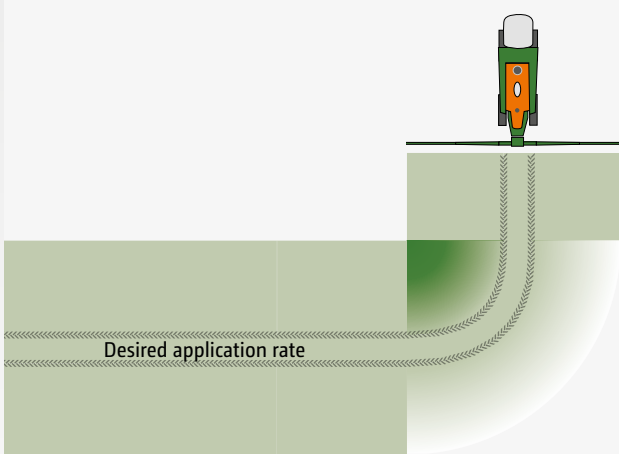

Without AmaSelect CurveControl – uneven application rate when negotiating bends

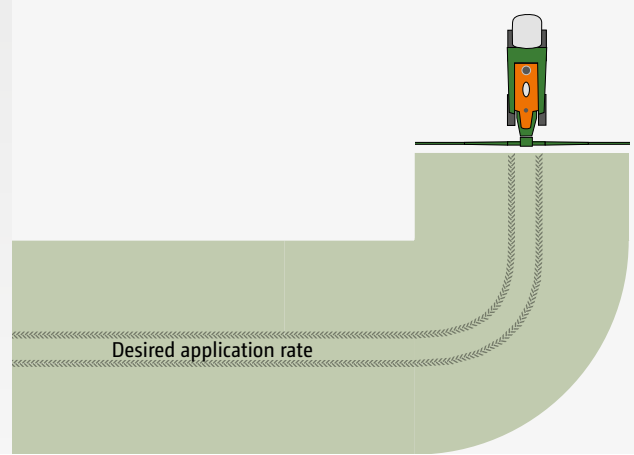

With AmaSelect CurveControl – a more even application rate when negotiating bends

Over- and under-dosing when negotiating bends

In the past, the distribution of plant protection products when driving round bends has led to an over-application on the inside of the bend and an under-application on the outside of the bend. The problem increases with increasing boom widths. Over-applying on the inside of the boom must be viewed more critically, as potential overdose levels of more than 300% are possible.

In addition to the nozzle pressure, AmaSelect CurveControl uses sensors to determine the curve radius and automatically calculates the pressure adjustment for the changed flow rate. The system then balances the application rate in the boom independently of the part-width section by means of automatic nozzle changing in the boom.

AmaSelect CurveControl

AmaSelect CurveControl offers a precise solution for keeping the application rate as constant as possible across the whole of the working width when driving round bends. The CurveControl function is equipped as standard in conjunction with AmaSelect individual nozzle control and ContourControl active boom guidance.

Benefits of AmaSelect CurveControl:

- ✔ Virtually uniform application rates when negotiating bends over the entire working width
- ✔ Optimum crop management
- ✔ Prevention of resistance caused by under-dosing

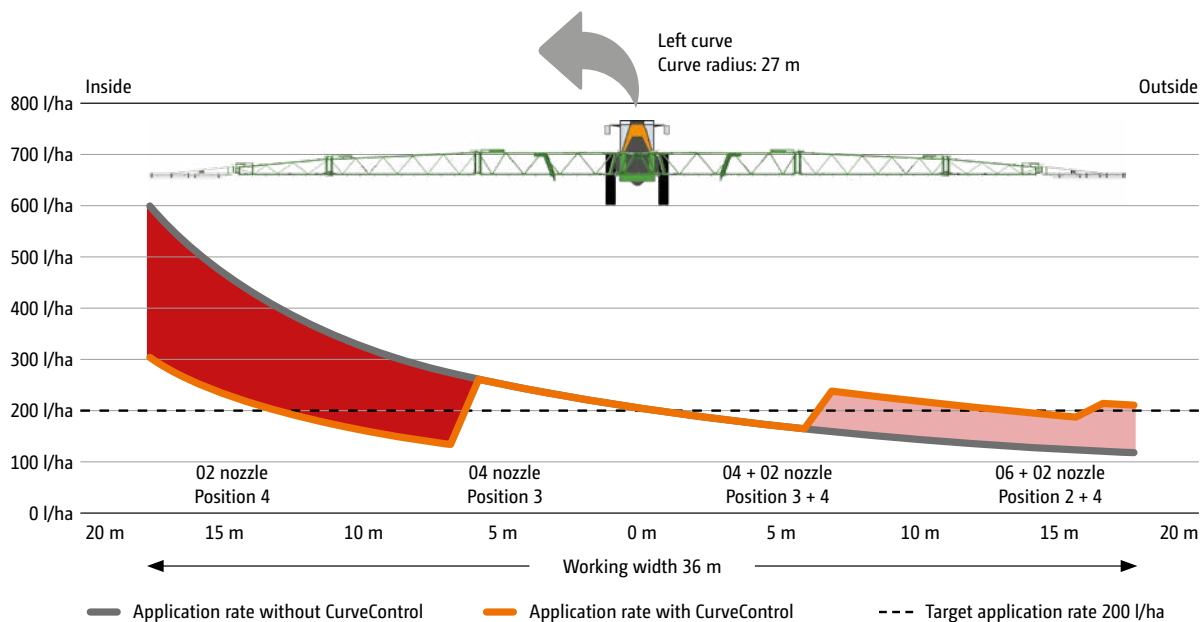

Comparison of application rates on bends with and without CurveControl (left hand curve)



AmaSelect Row

Accurate band spraying at the press of a button to reduce the use of plant protection agents



Row-specific band spraying in a potato crop

Row-specific band spraying in a sugar beet crop

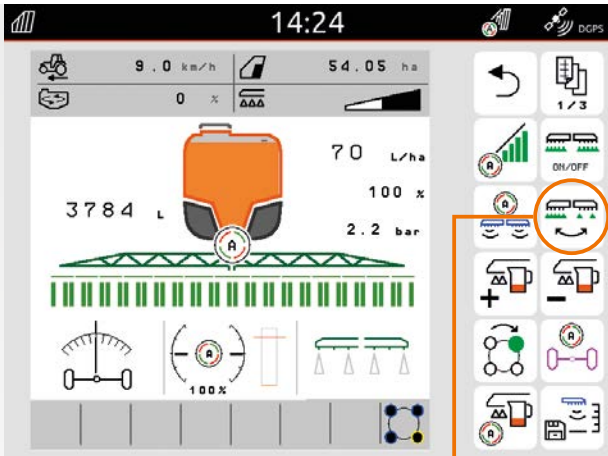

Easy switching between band spraying and full-width application at the push of a button

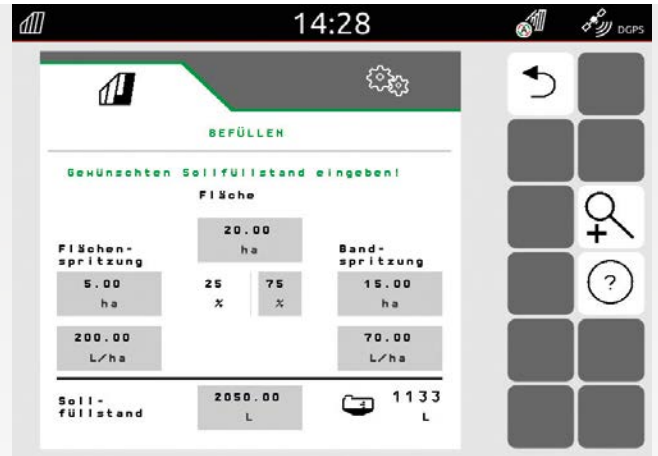

Useful fill menu for determining the required filling quantity

Row-specific band spraying

AMAZONE offers the AmaSelect Row function for the AmaSelect electric individual nozzle control for remote switching from full-area application to row-specific band spraying. Row-specific band spraying with special 40° nozzles makes it possible to reduce the consumption of plant protection agents by up to 65 %.

Different row spacings

Row specific applications in crops with a 50 cm row spacing can very easily be implemented without any further retooling. However, the optional off-set kit for the AmaSelect nozzle body to give a 25 cm nozzle spacing also enables band applications to be implemented in crops with a 75 cm row width. Only the nozzles at the desired spacing are switched on for that purpose. Alternative row widths, e.g. 45 cm for sugar beet, can also be realised with an additional nozzle arrangement and a connecting hose.

Maximum operational comfort

Via the fill menu, the area to be treated by band and full-width spraying as well as the desired application rates of the two types of spraying is stored, and the required filling quantity is automatically calculated so as to minimise residual spray volumes. The row spacing, spraying angle and application height of the nozzles are easily adjusted via a separate menu in the ISOBUS machine controller. The selection of the right nozzle and the associated nozzle positions to the band needing to be treated is carried out automatically. It is then possible to switch between band and full-width spraying in a matter of seconds at the push of a button on the ISOBUS terminal.

Benefits of AmaSelect Row:

- ✔ Highly efficient band spraying in row crops – and all at the touch of a button
- ✔ Different row spacings possible thanks to the optional off-set kit at 25 cm
- ✔ High operating comfort with an integrated filling menu with fill quantity calculation
- ✔ Reduction in plant protection agent usage by up to 65 %

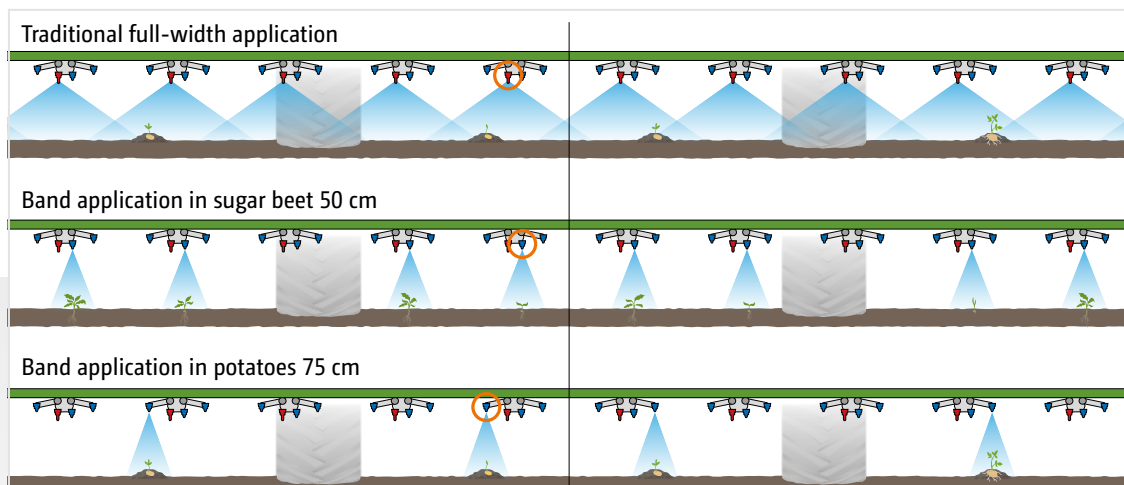

AmaSelect Row: Uniquely flexible options in plant protection

AmaSelect Row and CurveControl

The perfect combination in practice!



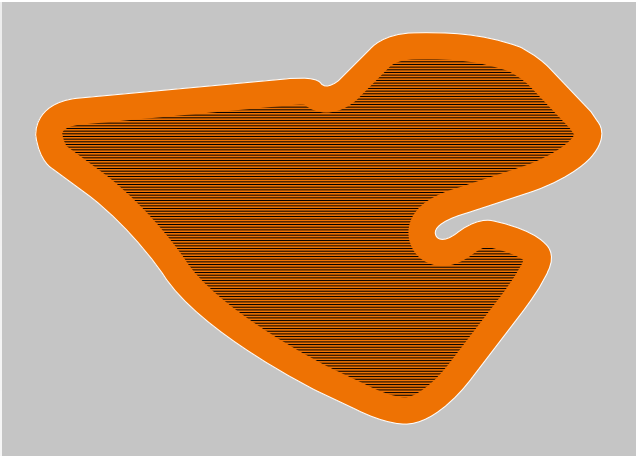

Band application in the inner area, full-width application with CurveControl in the outer area of the field

Full-width application with AmaSelect CurveControl in the outer area

Comprehensive full-width application is recommended for the outer area of fields. The advantages of CurveControl are particularly evident in fields with curves. Furthermore, obstacles at the edge of the field can be avoided during full-width application without any problems. In addition to this, the matching to the seed drill is not always exact on the headland. This has a negative effect on band spraying.

Changing to band application at the touch of a button

The material can then be sparingly applied in the inner area of the field with AmaSelect Row. The full-width application can be easily changed to band application on the terminal for this purpose. Absolutely straight rows and exact matching up to the seed drill are the prerequisites for the use of AmaSelect Row. The application rate is automatically adjusted in this respect.

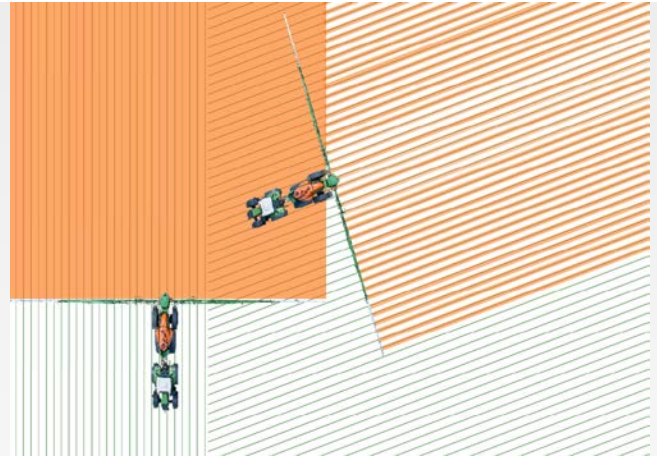

Individual nozzle control in band application for perfect application in wedge-shaped fields and short work

The particular features of band application

The perfect use of band application depends on several factors:

1. The nozzles must be at the right application height when they come on.
 - ✔ Automatic boom lowering with the AmaTron 4 ISOBUS terminal and GPS-Switch
2. Precise maintenance of the distance to the target surface required for a uniform band width and even concentration of the plant protection agent
 - ✔ ContourControl active boom guidance for the optimum target surface distance
3. Smooth boom ride over the entire working width
 - ✔ SwingStop or SwingStop plus boom tip swing compensation to reduce horizontal boom movements
4. Precise vertical alignment of the nozzles directly over the band
 - ✔ Flexible extension kit for precise alignment of the nozzles in all row spacings

AmaSelect Spot

Part-area, site-specific plant protection treatment on the basis of spot application maps



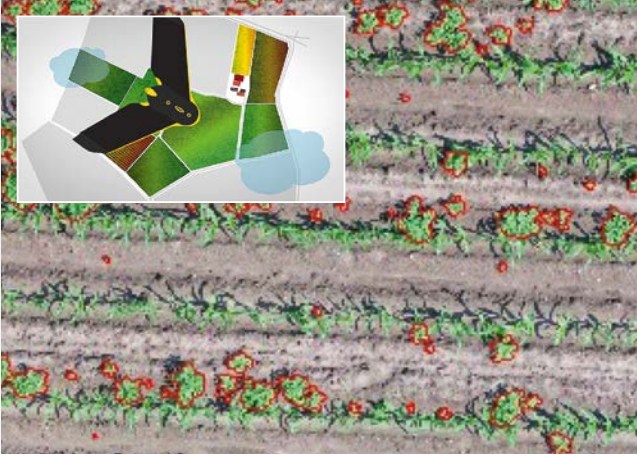

Processing of the spot application map in the ISOBUS terminal

Part-area, site-specific weed treatment

To reduce the use of crop protection agents, AMAZONE offers AmaSelect Spot, a individual nozzle control system which allows part-area, site-specific weed treatment based on highly accurate spot application maps. External service providers produce the spot maps.

Scanning the area and creation of spot maps for weed treatment

In the first step, the field to be treated is scanned and a spot application map created. Depending on the service provider, various processes are used for scanning the area in this first step, such as overflying with a drone, by satellite or via special sensor booms.

Targeted spot application

The second step is the treatment of the weed areas in the field. All that is required for this is to load the spot application map in the ISOBUS operator terminal. In contrast to full-area treatment with the AmaSelect individual nozzle control system, only those areas where weeds are present are treated during the pass.

Benefits of AmaSelect Spot:

- ✔ Precise spot treatment of weeds with a standard AMAZONE crop protection sprayer
- ✔ Reduction in plant protection agent usage by up to 80 %
- ✔ Better protection of the environment
- ✔ Minimal residual spray volumes, thanks to exact planning of the application rate using the spot application maps
- ✔ Prevention of resistance, thanks to small-area spot application with 100% concentration of plant protection agent

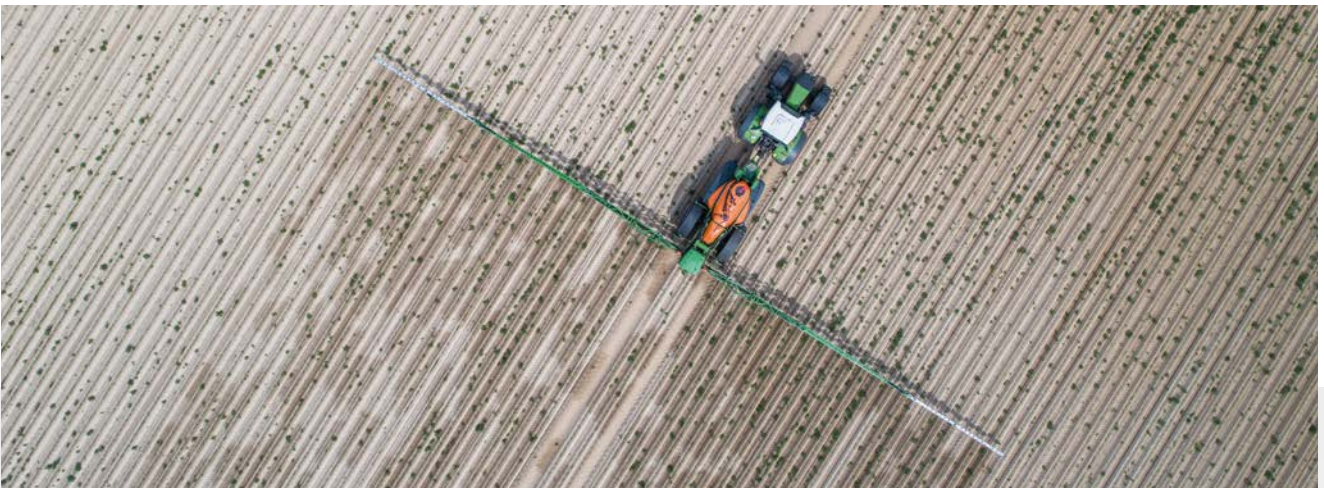

State-of-the-art crop protection technology in use: targeted treatment of volunteer potatoes in a carrot crop on the basis of a spot application map with a standard UX 5201 Super trailed sprayer

The right nozzle choice

The basis for success in crop protection



- ✔ Nozzle protection tubes are fitted as standard on the outer sections or, if desired, across the entire boom width and ensure optimum protection of the nozzle bodies.



Examples

- 1) Lechler IDN 120-025
- 2) TeeJet XRC 110-025
- 3) Injector flat fan nozzle AirMix 110-04



Less drift also at higher wind speeds

Injector nozzles (ID, TTI) have a relatively coarse droplet spectrum and are particularly versatile with regard to their range of application. A pressure range of 2 to 8 bar is possible. They are universally usable in all crops and all classifications. Because of the coarse droplet application, these nozzles can also be used in higher wind speeds.

If coverage quality is at the foreground of the application, the use of standard or anti-drift fine droplet nozzles, such as XR or AD, is recommended. Special care is required here due to their tendency to drift above 3 bar.

A good compromise is provided by the modern ID-K or Airmix compact injector nozzles. These have relatively little drift, but do not have too coarse a droplet spectrum and are operated at 2 to 4 bar.

When it comes to special coverage qualities, the double flat fan nozzle is an interesting alternative: the AVI Twin from Agrotop also produces droplets that are not too fine.

Everyone purchasing an AMAZONE crop protection sprayer receives, free of charge, an AMAZONE nozzle mounting tool that enables a much easier nozzle change.

The split spray pattern ensures a more even deposit on the front and back of the plant and makes sense maybe, for example, in ear treatment.

For speeds greater than 10 km/h, the TD HiSpeed nozzle with its asymmetrical spraying angle is becoming a new industry trend.

Distribution of the droplet size

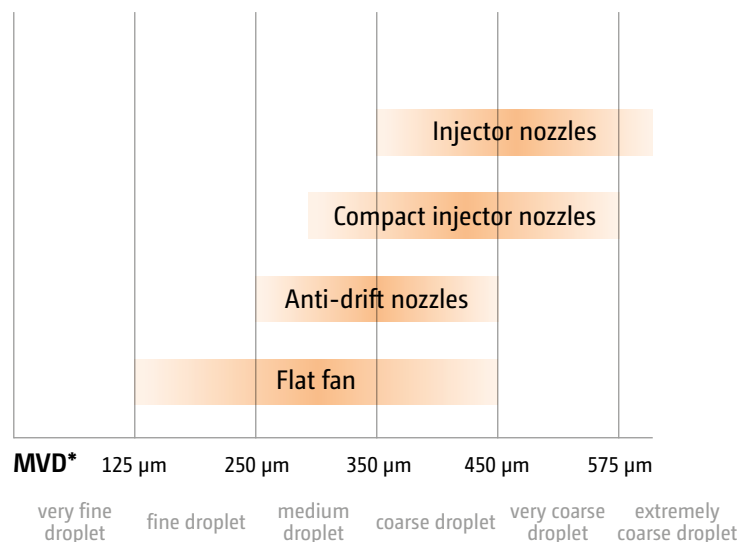

* mean volumetric diameter



Electric boundary nozzle switching

For environmentally-friendly spray application at the field edge

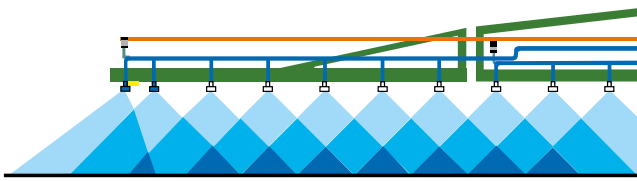

Additional nozzle switching

In order to extend the normal working width, an asymmetrical nozzle can also be switched on. This is particularly useful if the distances between tramlines are not precise enough.

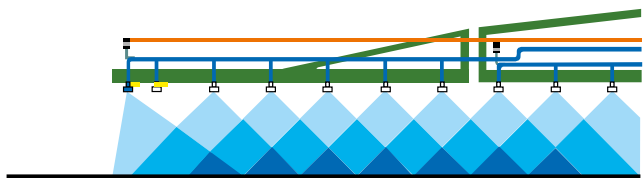

Boundary nozzle switching

For precision border spraying between two sensitive crops, the boundary nozzles can be used to make sure the spray pattern is accurately defined.

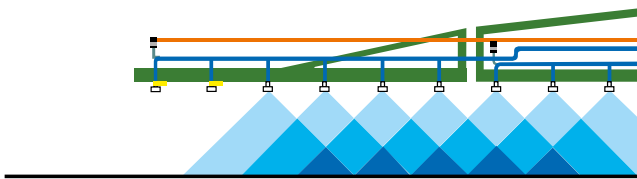

End nozzle switching

If a one metre buffer zone around the edge of the field needs to remain unsprayed due to distance constraints, end nozzle switching can be used.

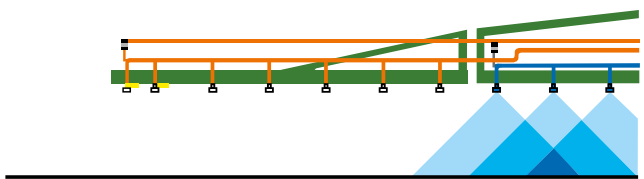

Outer part-width section switched off - DUS is active

Direct electric control of the boundary nozzles. Every nozzle body is integrated in the DUS circulation!



Drag hose equipment on the AmaSwitch individual nozzle control system with a quad nozzle body and an off-set kit on the Super-L2 boom



Liquid fertilisation

AMAZONE sprayers are particularly suitable for using liquid fertiliser: the use of high-quality plastics, the good paint finish and the use of stainless steel ensure a long service life, even when liquid fertiliser is used.

Drag hose equipment

The drag hose equipment for the Super-L boom consists of a drag hose set and can be used in conjunction with an AmaSwitch quad nozzle body or AmaSelect system plus an off-set kit for 25 cm nozzle spacing.

Stainless steel weights help keep the position of the drag hoses in the crop.

Multi-hole nozzles

For the distribution of liquid fertiliser in coarse droplet size, either multi-hole nozzles (3 or 7 hole) or the FD sluice nozzles are available on request.

Under-leaf spraying

Elegant solutions for successful under-leaf spraying are also possible in combination with AMAZONE crop protection sprayers. For example, the Dropleg system is a light and robust under-leaf spraying system which hangs freely between the rows.

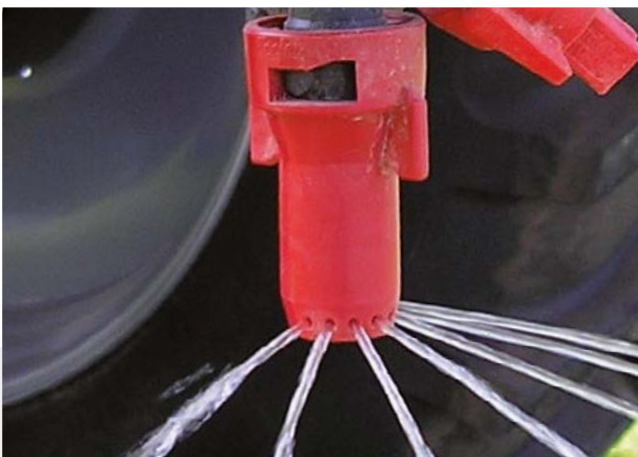

✔ 7 hole nozzle



✔ Dropleg system

Useful equipment to cope with many requirements





External wash kit

A spray lance on a 20 m long hose is used to clean off the outside of the self-propelled sprayer immediately after work whilst still in the field.

A 20-litre hand wash tank with a soap dispenser is available on the SmartCenter.

Compressed air supply system

A compressed air supply system with a small compressed-air reservoir is available for the Pantera 4504 as option for machine cleaning and tyre pressure monitoring.

The compressed air connection is located under the cab on the right-hand side of the machine.

Central lubrication system

The central lubrication system offers maximum convenience by automatically supplying all lubrication points without the need for a time-consuming search and manual lubrication. This enables maintenance work to be significantly reduced and operational reliability further improved.

The central lubrication system is mounted in a clearly visible location in front of the spray agent tank. Central operation takes place conveniently via the AmaDrive 7.0 vehicle terminal.

Manoeuvring device

A manoeuvring device is available for yard work.



AMAZONE – always in your vicinity

Your satisfaction is our challenge



The satisfaction of our customers is the most important objective

We rely on our nationwide network of expert, committed sales partners to achieve this. Also for service queries they are the reliable contact partner for farmers and contractors. Due to continuous training, our sales partners and service technicians are always up to date when it comes to looking after our state-of-the-art technology.

We provide you with a first class spare parts service

The spare parts centre in Tecklenburg-Leeden is the base for our worldwide spare parts logistics system. This ensures optimum availability of spare parts, even for older machines.

Orders for parts in stock at the Tecklenburg-Leeden spare parts centre which, if placed by 5 p.m., leave our premises the same day. 42,000 different spare parts and wearing metal parts are handled and stored via our modern warehousing system. Up to 1,000 orders are sent out to customers every day.



Better to choose the original right from the start

Your machines are subjected to extreme use! The quality of AMAZONE spare parts and wearing metal offers you the reliability and security you need for efficient soil tillage, precise sowing, professional fertilisation and successful crop protection.

Only original spare parts and wearing metal parts provide the durability and functionality expected from AMAZONE machinery. This guarantees an optimum quality of work. Original parts at fair prices pay for themselves in the end.

So opt for the original!

The advantages of original spare parts and wearing metal parts

- ✔ Quality and reliability
- ✔ Innovation and efficiency
- ✔ Immediate availability
- ✔ Higher resale value of the used machine



SmartLearning – Interactive driver training on the App or on a computer

With the "SmartLearning" tool as an App on your smartphone, on-line or as a download version for your computer, AMAZONE offers a useful function to make it easier for you to work efficiently with our machinery and terminals.

"SmartLearning" is an interactive training programme which gives drivers the opportunity to familiarise themselves with the operation of the machine before using it for the first time. However, experienced drivers can also refresh their knowledge here, in order to make even better use of the potential performance of their machine.

Via our homepage as an on-line version or for download: www.amazone.net/smartlearning

Or as an App on your smartphone:

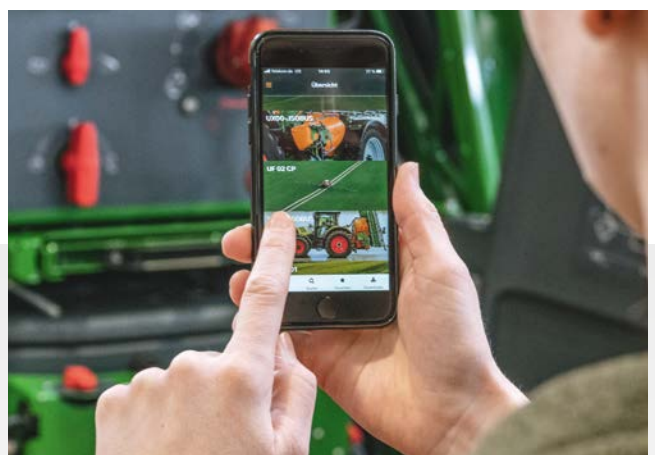

Tyres for Pantera 4504

| Dimensions | Pantera | Pantera-W | Pantera-H | Pantera-HW | Load index | Outer diameter in mm |
|------------|---------|-----------|-----------|------------|------------|----------------------|
| 300/95 R52 | X | X | X | X | 156 D | 1890 |
| 320/90 R54 | X | X | X | X | 156 B | 1948 |
| 340/85 R48 | X | X | | | 151 D | 1805 |
| 380/90 R46 | X | X | X | X | 168 D | 1842 |
| 380/90 R46 | X | X | X | X | 173 D | 1842 |
| 380/90 R50 | X | X | X | X | 170 D | 1956 |
| 380/90 R50 | X | X | X | X | 175 D | 1947 |
| 420/80 R46 | X | | | | 159 D | 1840 |
| 480/80 R42 | X | X | | | 156 B | 1840 |
| 480/80 R46 | X | X | X | X | 158 B | 1945 |
| 480/80 R46 | X | X | X | X | 177 D | 1943 |
| 520/85 R42 | X | X | X | X | 165 D | 1956 |
| 520/85 R42 | X | X | X | X | 162 B | 1951 |
| 520/85 R42 | X | X | X | X | 162 B | 1951 |
| 620/70 R38 | X | | | | 170 B | 1864 |
| 650/65 R38 | X | | | | 157 D | 1811 |
| 710/60 R38 | X | | | | 160 D | 1814 |

Illustrations, content and technical data are not binding and may differ depending on the level of equipment. Country-specific road traffic regulations apply and must be complied with, meaning that special approval may be required.

Tyres for Pantera 7004

| Dimensions | Pantera | Pantera-W | Load index | Outer diameter in mm |
|------------|---------|-----------|------------|----------------------|
| 380/90 R54 | X | X | 171 D | 2054 |
| 380/90 R54 | X | X | 176 D | 2050 |
| 420/95 R50 | X | X | 177 D | 2052 |
| 480/80 R50 | X | X | 166 D | 2050 |
| 480/80 R50 | X | X | 179 D | 2050 |
| 520/85 R46 | X | X | 170 D | 2052 |
| 620/70 R42 | X | | 166 D | 1935 |
| 650/65 R42 | X | | 170 D | 1940 |
| 650/65 R42 | X | | 165 D | 1936 |

Illustrations, content and technical data are not binding and may differ depending on the level of equipment. Country-specific road traffic regulations apply and must be complied with, meaning that special approval may be required.



Pantera 7004

Technical data: Pantera 4504



| Model | Pantera 4504 | Pantera 4504-W | Pantera 4504-H | Pantera 4504-HW |
|--|---|----------------|---|---|
| Nominal volume (l) / Actual volume (l) | 4,500 / 4,750 | | | |
| Fresh water tank (l) | 500 | | | |
| Working width (m) | 21 – 48 | | | |
| Delivery capacity pump (l/min) | 520 | | | |
| Max. suction capacity (l/min) | 700 | | | |
| Fuel tank capacity (l) | 290 | | | |
| DEF tank (l) | 20 | | | |
| Max. working speed (km/h) | 20 (30 optional) | | | |
| Transport speed (km/h) | up to 50 | | | |
| Length (m) (Transport position, incl. external wash down kit) | 8.60 | | | |
| Transport width (m) | 2.55 | 2.75 | 2.55 | 2.75 |
| Spraying height min./max. (m) with tyre sizes 380/90 R50 | 0.35 – 2.65 with lift module 0.35 – 3.35 | | 0.35 – 3.15 with lift module 0.35 – 3.85 | |
| Part-width sections min./max. (number) | 7 – 13 | | | |
| No. of sections with individual nozzle switching: Amaswitch or AmaSelect | up to 96 | | | |
| Unladen weight (kg) | 10,100 | 10,400 | 11,100 | 11,400 |
| Max. total weight (kg) | 17,200 (depending on tyres) | | | |
| Turning circle, all-wheel steer (m) | 4.50 | | | |
| Track width (m) with tyre sizes 380/90 R50 (offset depth + 50 mm) | 1.80 – 2.40 | 2.25 – 3.00 | 1.80 – 2.40 (down) 2.10 – 2.60 (up) | 2.25 – 3.00 (down) 2.45 – 3.20 (up) |
| Ground clearance (m) with tyre sizes 380/90 R50 | 1.20 | 1.15 | 1.25 / 1.70 in lower / upper working position | 1.25 / 1.70 in lower / upper working position |
| Engine power | max. 160 kW (218 hp) | | | |

Illustrations, content and technical data are not binding and may differ depending on the level of equipment. Country-specific road traffic regulations apply and must be complied with, meaning that special approval may be required.

Technical data: Pantera 7004



| Model | Pantera 7004 | Pantera 7004-W |
|---|---|----------------|
| Nominal volume (l) / Actual volume (l) | 6,600 / 7,000 | |
| Fresh water tank (l) | 500 | |
| Working width (m) | 24 – 48 | |
| Delivery capacity pump (l/min) | 610 | |
| Max. suction capacity (l/min) | 750 | |
| Fuel tank capacity (l) | 290 / 400 | |
| DEF tank (l) | 20 | |
| Max. working speed (km/h) | 20 (30 optional) | |
| Transport speed (km/h) | up to 50 | |
| Length (m) (Transport position, incl. external wash down kit) | 9.77 | |
| Transport width (m) | 2.55 | 2.75 |
| Spraying height min./max. (m) with tyre sizes 380/90 R50 | 0.35 – 2.75 with lift module 0.35 – 3.45 | |
| Part-width sections min./max. (number) | 7 – 13 | |
| No. of sections with individual nozzle switching: AmaSwitch or AmaSelect | up to 96 | |
| Unladen weight (kg) | approx. 12.000 kg depending on the level of equipment | |
| Max. total weight (kg) | 20,000 | |
| Turning circle, all-wheel steer (m) | 4.50 | |
| Track width (m) with tyre sizes 380/90 R50 (offset depth + 50 mm) | 2.00 – 2.75 | 2.25 – 3.00 |
| Ground clearance (m) with tyre sizes 380/90 R50 | 1.30 | |
| Engine power | max. 225 kW (306 hp) | |

Illustrations, content and technical data are not binding and may differ depending on the level of equipment. Country-specific road traffic regulations apply and must be complied with, meaning that special approval may be required.



AMAZONE



AMAZONEN-WERKE H. DREYER SE & Co. KG
P. O. Box 51 · 49202 Hasbergen-Gaste/Germany
Phone +49 (0)5405 501-0 · Fax +49 (0)5405 501-193